

80

Water & steam boilers
for use with Gas, Light Oil, &
Gas/Light Oil - Fired Burners

Burner specifications and data

Webster burners

Model **WJB** Flame retention type, for gas, light oil or combination gas/oil firing

Model **WJB-Gas**

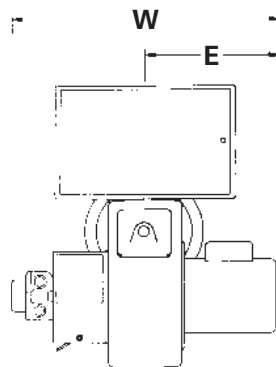
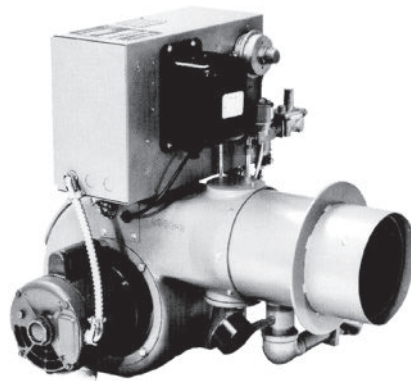

Model **WJB-Gas/Oil**

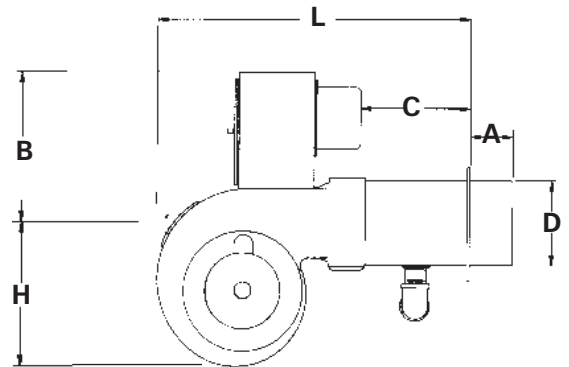
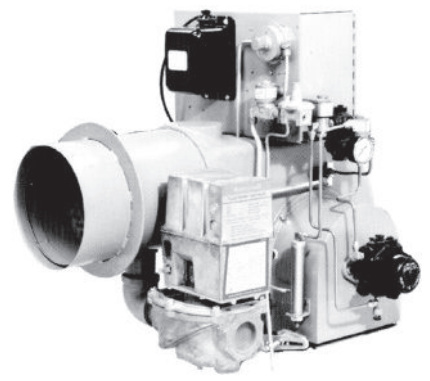

Dimensions (inches)

Burner model number	A	B	C	D	E	H	L	W	Approximate shipping weight
WJB1	4.00	14.00	9.00	7.25	11.00	11.00	25.00	23.00	155-160 lbs.



Boiler Model Number 80 Series 1	Burner Input (forced draft)		Positive pressure in firebox In. W.C.	Standard burner model designation			Standard combustion control			Standard control system			Burner motor 3450 RPM	
	No. 2 Oil GPH	Gas MBH		Gas	Light oil	Gas/ Light oil	Gas	Light oil	Gas/ Light oil	Gas	Light oil	Gas/ Light oil	H.P.	Standard voltage
580	4.45	639	0.28	WJB1G-03	WJB1O-03	WJB1C-03	RM7897A	R7184A	RM7897C	A	A	A/A	1/3	120/60/1
680	5.50	787	0.27	WJB1G-03	WJB1O-03	WJB1C-03	RM7897A	R7184A	RM7897C	A	A	A/A	1/3	120/60/1
780	6.50	935	0.27	WJB1G-03	WJB1O-03	WJB1C-03	RM7897A	R7184A	RM7897C	A	A	A/A	1/3	120/60/1
880	7.50	1082	0.27	WJB1G-03	WJB1O-03	WJB1C-03	RM7897A	R7184A	RM7897C	A	L	L/L	1/3	120/60/1
980	8.50	1230	0.27	WJB1G-03	WJB1O-03	WJB1C-05	RM7897A	R7184A	RM7897C	L	L	L/L	1/3 / 1/2	120/60/1
1080	9.60	1378	0.26	WJB1G-05	WJB1O-05	WJB1C-05	RM7897A	R7184A	RM7897C	L	L	L/L	1/2	120/60/1
1180	10.60	1526	0.26	WJB1G-05	WJB1O-05	WJB1C-07	RM7897A	R7184A	RM7897C	L	L	L/L	1/2 / 3/4	120/60/1
1280	11.60	1674	0.26	WJB1G-05	WJB1O-05	WJB1C-07	RM7897A	R7184A	RM7897C	L	L	L/L	1/2 / 3/4	120/60/1

Standard Gas Components and Sizes in Inches						
Boiler Model Number	Manual hand valve (point of field connection)	Gas Pressure regulator	Safety gas valve	Motorized operating gas valve	Diaphragm operating gas valve	Manual checking gas valve
580-780	1"	1"	1"	Optional	1"	1"
880-980	1"	1"	1-1/4"	1-1/4"	N.A.	1-1/4"
1080	1-1/4"	1-1/4"	1-1/2"	1-1/2"	N.A.	1-1/2"
1180-1280	1-1/2"	1-1/2"	1-1/2"	1-1/2"	N.A.	1-1/2"

- Notes**
- Burner capacities listed for elevations up to 2,000 feet. For higher elevations, consult local Weil-McLain distributor/agent or sales office.
 - Light oil ratings based on No. 2 fuel oil with heating value of 140,000 Btu per gallon.
 - Gas ratings based on natural gas with heating value of 1,000 Btu per cubic foot and specific gravity of 0.60. Gas burners for other gases are available. Consult local Weil-McLain distributor/agent or sales office.
 - Boiler-burner unit to be adjusted to achieve +0.10 inches W.C. pressure at flue collar, resulting in positive pressure in firebox as listed.
 - Minimum gas pressures listed are subject to variations due to job conditions. Gas burners for other gas pressures are available. Consult local Weil-McLain distributor/agent or sales office.
 - Gas orifice pressures shown are for initial start-up. Final pressures should be determined after checking actual gas flow and combustion readings.
 - Gas Control Systems:
 - A (OO): On-off operation. Single-position air and fuel.
 - L (LHO): On-off operation, low fire start, high fire run. Air controlled by damper arm on motorized gas valve. (Available on 680-1280 only).
 - H (LHL): Low-high-low-off firing conditions. Two-position air controlled by damper arm on motorized gas valve. (Available on 780-1280 only).
 - M (MOD): On-off operation, with proven low fire start. Proportional motor drives fuel metering valve and combustion air damper according to the firing conditions. Fixed damper pre-purge. (Available on 780-1280 only).
 - Light Oil Control Systems:
 - A (OO): On-off operation, fixed air. Single-position air and fuel.
 - L (LHO): On-off operation, low fire start, high fire run. Two-position air, two-position oil. (Available on 680-1280 only).
 - H (LHL): Low-high-low-off firing conditions. Two-position air, two-position oil. (Available on 780-1280 only).
 - M (MOD): On-off operation, with proven low fire start. Proportional motor drives fuel metering valve and combustion air damper according to the firing conditions. Fixed damper pre-purge. (Available on 780-1280 only).



Burner Specification and Data Sheet

Boiler Model Number 80 Series 1	Pressure drop thru gas train In. W.C.	Gas orifice pressure In. W.C.	Gas pressure required at gas control inlet Inches W.C.		Initial air damper setting inches		Oil nozzle(s)				Oil pressures PSIG			Fuel unit Burner-motor driven 3450 RPM		
			Min.	Max.	Low fire	High fire	Qty	GPH @ 100 PSIG	Brand	Type	Spray angle	Pump capacity	High fire	Low fire	Type	Gear GPH
580	2.30	2.30	4.60	14.00	---	3/4	1	3.00	Hago	P	60°	300	225	----	22R220	45
680	3.50	3.20	6.70	14.00	---	1/2	1	3.50	Hago	SS	45°	300	250	100-150	22R220	45
780	4.90	1.50	6.40	14.00	1/4	9/16	1	4.00	Hago	SS	45°	300	270	100-150	22R220	45
880	3.30	2.20	5.50	28.00	1/4	1-1/4	1	4.50	Hago	P	45°	300	280	100-150	22R220	45
980	4.20	2.30	6.50	28.00	1/4	1-3/16	1	5.00	Hago	P	45°	300	290	100-150	22R220	45
1080	3.40	2.90	6.30	28.00	5/16	1-3/8	1	5.50	Hago	P	45°	300	305	100-150	22R220	45
1180	2.40	3.60	6.00	28.00	3/8	1-1/2	1	6.50	Hago	P	60°	300	270	100-150	22R220	45
1280	2.90	2.90	5.80	28.00	7/16	1-3/8	2	3.50	Hago	P	60°	300	280	100-150	22R220	45

Notes

- Burner capacities listed for elevations up to 2,000 feet. For higher elevations, consult local Weil-McLain distributor/agent or sales office.
- Light oil ratings based on No. 2 fuel oil with heating value of 140,000 Btu per gallon.
- Gas ratings based on natural gas with heating value of 1,000 Btu per cubic foot and specific gravity of 0.60. Gas burners for other gases are available. Consult local Weil-McLain distributor/agent or sales office.
- Boiler-burner unit to be adjusted to achieve +0.10 inches W.C. pressure at flue collar, resulting in positive pressure in firebox as listed.
- Minimum gas pressures listed are subject to variations due to job conditions. Gas burners for other gas pressures are available. Consult local Weil-McLain distributor/agent or sales office.
- Gas orifice pressures shown are for initial start-up. Final pressures should be determined after checking actual gas flow and combustion readings.
- Gas Control Systems:
 - A (OO): On-off operation. Single-position air and fuel.
 - L (LHO): On-off operation, low fire start, high fire run. Air controlled by damper arm on motorized gas valve. (Available on 680-1280 only).
 - H (LHL): Low-high-low-off firing conditions. Two-position air controlled by damper arm on motorized gas valve. (Available on 780-1280 only).
 - M (MOD): On-off operation, with proven low fire start. Proportional motor drives fuel metering valve and combustion air damper according to the firing conditions. Fixed damper pre-purge. (Available on 780-1280 only).
- Light Oil Control Systems:
 - A (OO): On-off operation, fixed air. Single-position air and fuel.
 - L (LHO): On-off operation, low fire start, high fire run. Two-position air, two-position oil. (Available on 680-1280 only).
 - H (LHL): Low-high-low-off firing conditions. Two-position air, two-position oil. (Available on 780-1280 only).
 - M (MOD): On-off operation, with proven low fire start. Proportional motor drives fuel metering valve and combustion air damper according to the firing conditions. Fixed damper pre-purge. (Available on 780-1280 only).
- Gas/Light Oil Control Systems:
 - A/A (OO): Combines gas and light oil characteristics listed above.
 - L/L (LHO/LHO): Combines gas and light oil characteristics listed above. (Available on 680-1280 only).
 - H/H (LHL/LHL): Combines gas and light oil characteristics listed above. (Available on 780-1280 only).
 - M/M (MOD/MOD): Combines gas and light oil characteristics listed above. (Available on 780-1280 only).
- 120/60/1 control circuit is used for all burners.
- Control circuit transformer is available as an option.
- Motor starter contactor will be furnished for all burners.
- Combustion Controls:
 - a) R7184A combustion control uses cadmium cell for flame detector to monitor oil burner flame, also furnishes intermittent ignition.
 - b) RM7897 flame safeguard control uses ultraviolet electronic flame detector to monitor gas or oil burner flame and provides pre-purge programming. "A" models provide intermittent pilot; "C" models provide interrupted pilot and RUN/TEST switch.



Flame Safeguards Provided with Listed Control Systems by Code

LIGHT OIL BURNERS

Boiler Model Number	UL				FM				CSD-1				IRI			
	A(OO)	LHO	LHL	MOD	A(OO)	LHO	LHL	MOD	A(OO)	LHO	LHL	MOD	A(OO)	LHO	LHL	MOD
580-780	R7184A	---	---	---	R7184A	---	---	---	RM7897A	---	---	---	RM7897C	---	---	---
880-1280	---	R7184A	R7184A	R7184A	---	R7184A	R7184A	R7184A	---	RM7897A	RM7897A	RM7897A	---	RM7897C	RM7897C	RM7840L

GAS BURNERS

Boiler Model Number	UL				FM				CSD-1				IRI			
	A(OO)	LHO	LHL	MOD	A(OO)	LHO	LHL	MOD	A(OO)	LHO	LHL	MOD	A(OO)	LHO	LHL	MOD
580-780	RM7897A	---	---	---	RM7897A	---	---	---	RM7897A	---	---	---	RM7897C	---	---	---
880-1280	---	RM7897A	RM7897A	RM7897A	---	RM7897A	RM7897A	RM7897A	---	RM7897A	RM7897A	RM7897A	---	RM7897C	RM7897C	RM7840L

COMBINATION GAS/OIL BURNERS

Boiler Model Number	UL				FM				CSD-1				IRI			
	A(OO)	LHO	LHL	MOD	A(OO)	LHO	LHL	MOD	A(OO)	LHO	LHL	MOD	A(OO)	LHO	LHL	MOD
580-780	RM7897C	---	---	---	RM7897C	---	---	---	RM7897C	---	---	---	RM7897C	---	---	---
880-1280	---	RM7897C	RM7897C	RM7897C	---	RM7897C	RM7897C	RM7897C	---	RM7897C	RM7897C	RM7897C	---	RM7897C	RM7897C	RM7840L