



LGB *Gas-fired boiler*

Control Supplement

LGB-4 & LGB-5 Series 2 – Propane gas Universal Control System



Contents

Installation	2
Conversion (Natural/Propane) ...	2
Gas piping	3
Wiring	4
Operating instructions	6
Verification testing	7
Parts	8

Refer to
**LGB • Installation •
 Start-Up • Service •
 Parts Manual**
for additional informatio

These terms are used throughout this manual to bring attention to the presence of hazards of various risk levels or to important information concerning the life of the product.

WARNING

Indicates presence of hazards that can cause severe personal injury, death or substantial property damage.

NOTICE

Indicates special instructions on installation, operation or maintenance that are important but not related to personal injury or property.

WARNING

Control Supplement must only be used by a qualified installer/service technician. Read all instructions before installing. Failure to follow all instructions in proper order can cause severe personal injury, death or substantial property damage.



I New installation Conversion from natural gas to propane gas

1. Remove all burners from base box assembly. Remove 3.95 mm natural gas main burner orifices in manifold. Install 2.40 mm propane main burner orifices. Use pipe dope sparingly only on male ends. Use pipe dope compatible with propane gases. Do not overtighten orifices.
2. Install pilot burners. See Figure 1. Follow Table 1 for electronic pilot burner and standing pilot burner (Q327) locations on manifold.
3. Install gas controls and ignition control as shown in Figure 3 on page 7 or Figure 4 on page 8. Use Propane Control Carton, Number 4 and 5.
4. Attach pilot switch box to interior jacket panel (see Figure 3 or 4, pages 7 and 8). Connect thermocouple from standing pilot to switch box. Cut 60" pilot tubing into 2 pieces to make connections from pilot valve to pilot switch box and from pilot switch box to standing pilot.
5. Attach:
 - a. 550-223-710 label above or to the left of boiler operating instruction label. Place so that this label reads first.
 - b. 550-223-796 label next to rating label.
 - c. Wiring diagram on door.
 - d. Canada only - mount rating plate on interior jacket panel.
6. Proceed to section III, Gas Piping.

II Existing installation Conversion from natural gas to propane gas



This conversion is to be installed by a Weil-McLain distributor or other qualified agency in accordance with the manufacturer's instructions and all codes and requirements of the authority having jurisdiction. Failure to follow instructions could result in serious injury or property damage. The qualified agency performing this work assumes responsibility for this conversion.



For your safety, turn off electrical power supply before making any electrical connections to avoid possible electrical shock hazard.

1. These instructions are for use with Propane Control Carton Number 4 and 5.
 2. Remove jacket door(s) and access panel.
 3. Disconnect wiring and tubing from existing pilot burner.
 4. Remove all burners. Remove 3.95 mm natural gas main burner orifices in manifold. Install 2.40 mm propane main burner orifices. Use pipe dope sparingly only on male ends. Use pipe dope compatible with propane gases. Do not overtighten orifices.
 5. Remove and discard existing electronic pilot burner from pilot burner tube. Replace with electronic pilot burner in carton.
 6. Attach Q327 standing pilot to burner tube in kit. Connect pilot tubing and thermocouple to pilot.
 7. Re-install burners. See Table 1 for location of pilot burners.
 8. Attach pilot switch box to jacket. See Figure 3 or 4, pages 7 and 8. Connect thermocouple to pilot switch box. Cut 60" pilot tubing into 2 pieces to make connections from tee in pilot line to pilot switch box and from pilot switch box to standing pilot.
 9. Remove natural gas valve train.
 10. Install propane gas valve train and fittings from carton. (See paragraph 4, page 3 of this Supplement.)
 11. Re-install access panel(s).
 12. See Figure 3 or 4, pages 7 and 8, for propane piping.
 13. Wire per wiring diagram, pages 4 – 5. Add splices as needed.
- Attach:
- a. 550-223-710 label above or to the left of boiler operating instruction label. Place so that this label reads first.
 - b. 550-223-796 label next to rating label.
 - c. Wiring diagram over diagram on door (one on each base).
14. To place in operation, follow instructions on constant burner pilot light-up label and boiler operating label.
 15. Replace jacket doors.



Figure 1

Pilot burner assembly

Table 1

Pilot and flame sensor locations

Boiler model	Electronic pilot burner *	Standing pilot burner *	Propane carton
LGB-4	4	2	4 and 5
LGB-5	5	2	4 and 5

* Burner position, counting from left to right

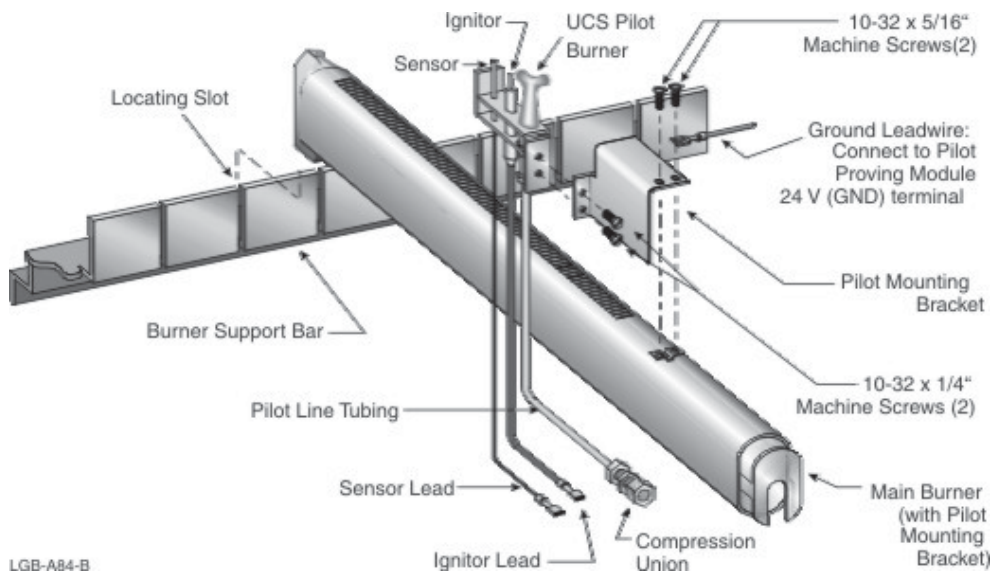

LGB-A84-B

III

Gas piping

1. Contact gas supplier to size pipes, tanks and regulator.
 - a. Inlet gas pressure to manual main shut-off gas valve minimum 11" W.C., maximum 13" W.C.
 - b. If pressure to gas valve exceeds 13" W.C., install 100% lock-up gas pressure regulator upstream of hand valve.
2. Remove knockout disc from jacket panel side to which gas supply will be piped.
3. Follow good piping practices.
4. Pipe joint compound (pipe dope) must be resistant to corrosive action of liquefied petroleum gases. Apply sparingly only to male threads of pipe joints.
5. Install drip leg at inlet of gas connection to boiler. Where local code/utility requires, extend drip leg to floor.
6. Install ground joint union when required for servicing.
7. Support piping by hangers, not by boiler or its accessories.
8. Purge all air from supply piping.
9. Before operating boiler, check boiler and its gas connections for leaks.



WARNING

Do not check for gas leaks with an open flame - use bubble test. Failure to use bubble test or check for leaks can cause severe personal injury, death or substantial property damage.

- a. Close manual main shut-off valve during any pressure testing greater than 13" W.C.
 - b. Disconnect boiler and gas valve from gas supply piping during any pressure test greater than 13" W.C.
10. In Canada - manual main shut-off valve must be identified by installer.



IV Wiring

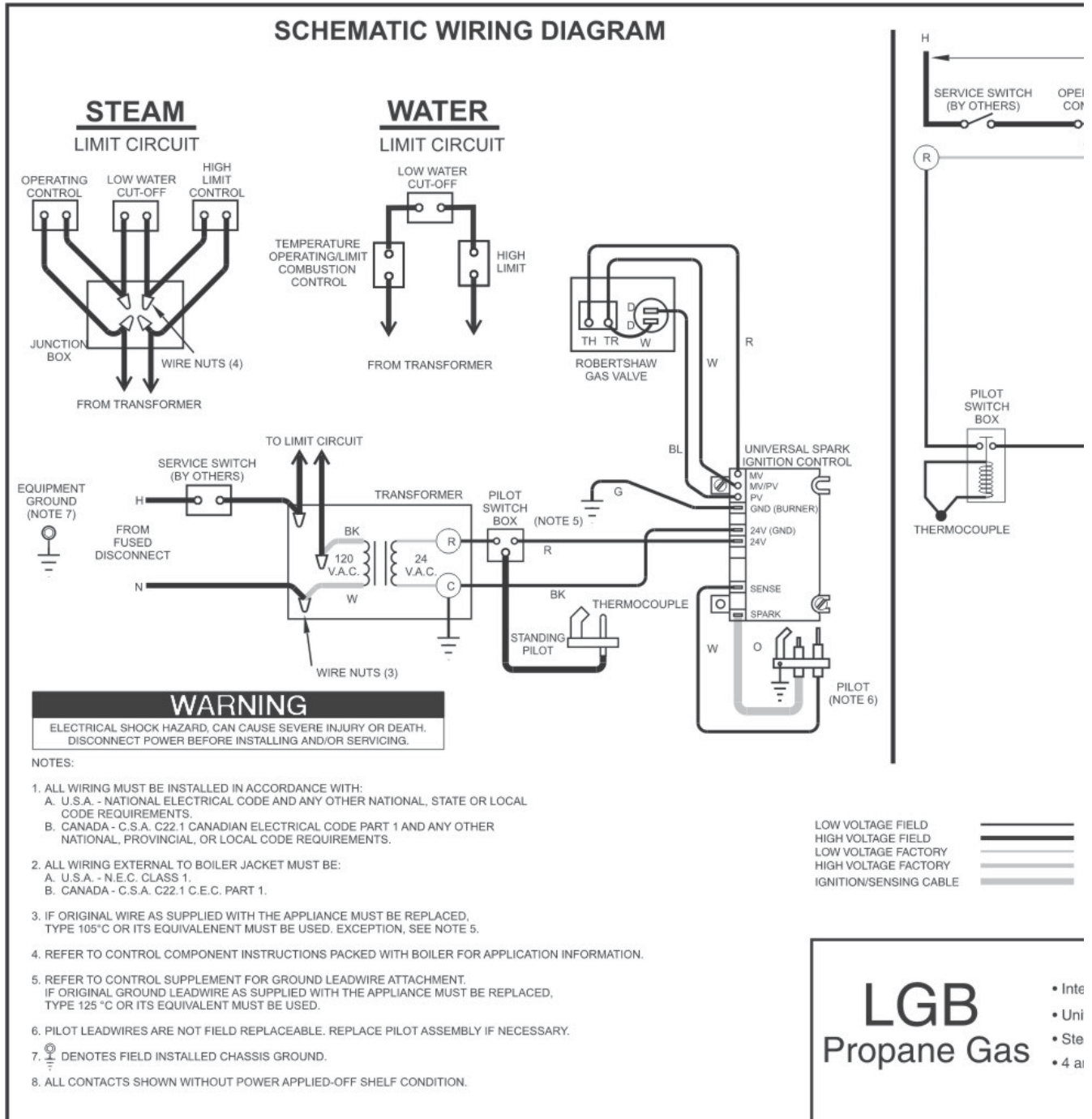
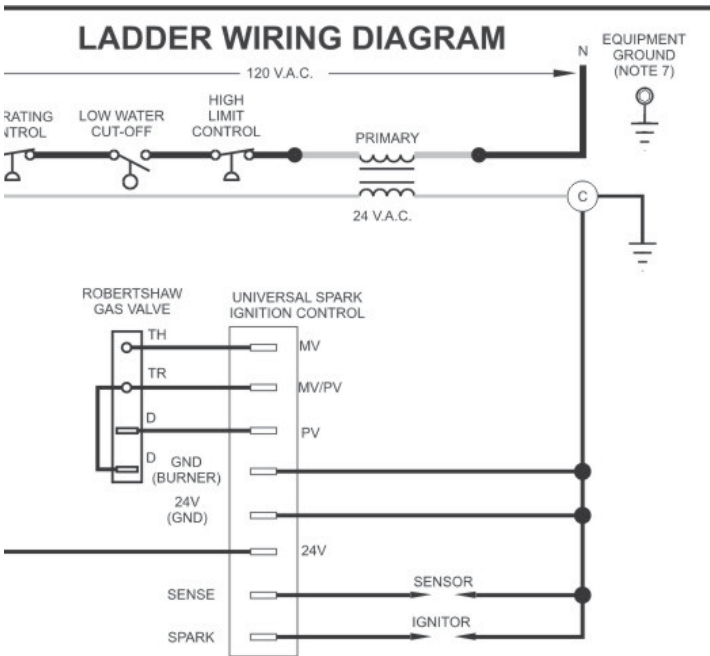



Figure 2 Wiring diagram



WARNING

For your safety, turn off power supply before making electrical connections to avoid possible electrical shock hazard.

WARNING

Label all wires prior to disconnection when servicing controls. Wiring errors can cause improper and dangerous operation resulting in severe personal injury, death or substantial property damage.

Wiring requirements

All wiring must be installed according to requirements of the National Electrical Code and any national, state or local code requirements having jurisdiction. All wiring external to boiler jacket must be N.E.C. Class 1. The boiler must be electrically grounded according to the National Electrical Code, ANSI/NFPA No. 70 latest edition. Use 105°C thermoplastic wire, or equivalent, if any original wire must be replaced. GND (burner) lead wires must be 125°C wire.

Canadian installations must conform to CSA C22.1 Canadian Electrical Code Part 1 and any local or provincial codes.

Wiring to boiler must be No. 14 gauge or heavier. Install in conduit.

A separate electrical circuit with a fused disconnect switch (15 amp. recommended) should be used for the boiler.

Wiring procedure

- Determine right or left electrical supply wiring.
- Attach electrical junction box to inside jacket end panel. Screws and nuts are provided.
- Attach control transformer to junction box.
- Complete wiring per wiring diagram, Figure 2, pages 4 and 5.
- Install ignition control ground connection as shown in Figure 1 and wiring diagram, Figure 2.
- In Canada — attach chain between junction box and transformer with S-hooks.

NOTICE

"Hot" side of line voltage to boiler must be wired directly to limit circuit, then fed to transformer primary.

Sequence of operation

1. Operating control begins start-up sequence.
 - a. Limit control contacts are closed.
2. Ignition control module energized.

NOTICE

On failure to sense pilot flame, Ignition Control will wait 5 minutes then retry for ignition. On failure of the thermocouple to sense flame at the standing pilot, the Pilot Switch Box will open the circuit, preventing operation of the boiler and requiring the pilot to be manually ignited before restarting.

- a. Pilot gas valve opens (provided Pilot Switch Box is satisfied of flame on standing pilot).
- b. Pilot ignition spark begins.
- c. Pilot ignites.
- d. Pilot proves.
- e. Main gas valve opens.
- f. Main burners ignite.

3. Boiler shuts down when operating control satisfied.

Intermittent Pilot
Universal Control System
for Gas or Water
Heating



WEIL-McLAIN

Weil-McLain • 500 Blaine St. • Michigan City, IN 46360-2388

PART NUMBER 550-101-133/0104



IV Operating instructions

⚠ WARNING

- A. This boiler is equipped with a pilot which must be lighted by hand. When lighting the pilot, follow these instructions exactly. The gas supply to this pilot is controlled by the *Pilot Switch Box*. This boiler is also equipped with an ignition device which automatically lights a second pilot. The gas supply to this pilot is controlled by the *Gas Control*. Do not try to light this pilot by hand.
- B. **BEFORE LIGHTING THE MANUAL PILOT**, smell all around the appliance area for gas. Be sure to smell next to the floor because some gas is heavier than air and will settle on the floor.
- WHAT TO DO IF YOU SMELL GAS**
- Do not try to light any appliance.
 - Do not touch any electric switch; do not use any phone in your building.
 - Immediately call your gas supplier from a neighbor's phone. Follow the gas supplier's instructions.
 - If you cannot reach your gas supplier, call the fire department.
- C. Use only your hand to turn the gas control knob. Never use tools. If the knob will not turn by hand, don't try to repair it, call a qualified service technician. Force or attempted repair may result in a fire or explosion.
- D. Do not use this appliance if any part has been under water. Immediately call a qualified service technician to inspect the appliance and to replace any part of the control system and any gas control, which has been under water.

Starting boiler

1. STOP! Read the safety information above.
2. Set the thermostat to lowest setting.
3. Turn off all electrical power to the appliance.
4. Remove the *Base Access Shield*.
5. Close *Pilot Shutoff Valve* connected to *Gas Hand Valve*. Close *Gas Hand Valve*.
6. Wait five (5) minutes to clear out any gas. Then smell for gas, including near the floor. If you smell gas, STOP! Follow "B" in the safety information above. If you don't smell gas, go to the next step.
7. Open *Pilot Shutoff Valve*.
8. Press and hold the reset lever on the *Pilot Switch Box*. Manually light the pilot while holding the lever down. Air in the gas supply line will have to purge through the line before sufficient gas will reach the pilot.
9. After purging all air, hold the *Pilot Switch Box* lever for about 1 minute to heat the thermocouple.
10. Release the *Pilot Switch Box* lever. The pilot should remain lit.
11. Open the *Gas Hand Valve* and follow the sequence below.
12. This appliance is also equipped with an ignition device which automatically lights the second pilot. Do not try to light this pilot by hand.
13. Turn *Gas Control* knob clockwise to "OFF".
14. Wait five (5) minutes to clear out any gas. Then smell for gas, including near the floor. If you smell gas, STOP! Follow "B" in the safety information above on this label. If you don't smell gas, go to the next step.
15. Turn *Gas Control* knob counterclockwise to "ON".
16. Turn on all electric power to the appliance.
17. Set thermostat to desired setting.
18. If the appliance will not operate, turn off gas to the boiler by closing the *Gas Hand Valve* and *Pilot Shutoff Valve*. Rotate the *Gas Control* knob clockwise to "OFF". Call your service technician or gas supplier.
19. Replace *Base Access Shield* and *Front Panel*.

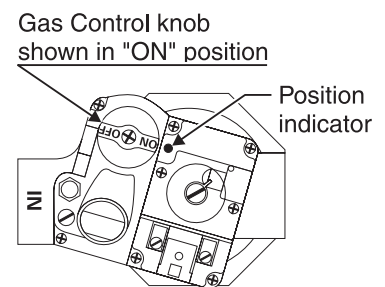
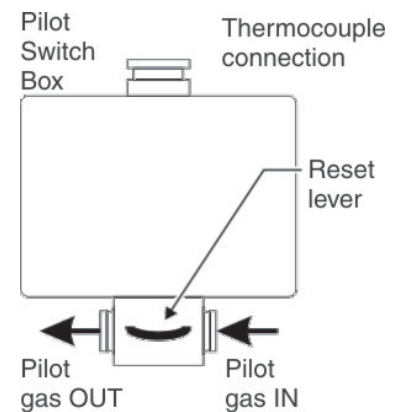



V

Verification testing

WARNING

Before starting boiler for the first time and at least annually (during annual inspection and start-up), follow the procedures below to verify boiler controls are operating correctly and that automatic gas valve properly shuts off gas flow. Failure to verify boiler operation could result in severe personal injury, death or substantial property damage.

Manual test firing valve

This boiler is equipped with a manual test firing valve — the manual gas valve piped between the gas manifold and the automatic gas valve. Closing the manual test firing valve allows verification of proper boiler operation without allowing gas flow to the manifold and allows leak testing of the automatic gas valve. Follow the procedures below.

Verify boiler control sequence

1. Follow the Operating Instructions in this Supplement to start the boiler, but **do not open the manual test firing valve**. Open all other manual gas valves as instructed. Leave the manual test firing valve closed.
2. The automatic pilot burner should light.
3. After the pilot lights, the boiler controls should activate the automatic gas valve. Use a voltmeter to verify voltage to automatic valve.
4. With no gas flow to the manifold, the boiler ignition controls should turn off the automatic gas valve after main flame ignition trial. Use a voltmeter to verify voltage to automatic valve is turned off.

Leak test automatic gas valve

1. Close manual test firing valve.
2. Open the service valve. Press down and turn automatic gas valve knob (or lever) to ON.
3. Install a hose barb into a pressure tap downstream of the automatic gas valve. Allow any accumulated gas in the line to vent off. Then connect a U-tube manometer. If the valve seals properly, there should be no gas pressure present. Remove manometer and hose barb and replace pipe plug in pressure tap.
4. Remove the manometer and plug any open pressure taps.
5. Follow Operating Instructions to place boiler in service.

WARNING

Replace any defective components. Do not attempt to operate boiler or leave boiler in operation if any component is found to be defective or to operate incorrectly. Failure to comply could result in severe personal injury, death, or substantial property damage.



VI

Parts list

Figure 3
Control and gas components

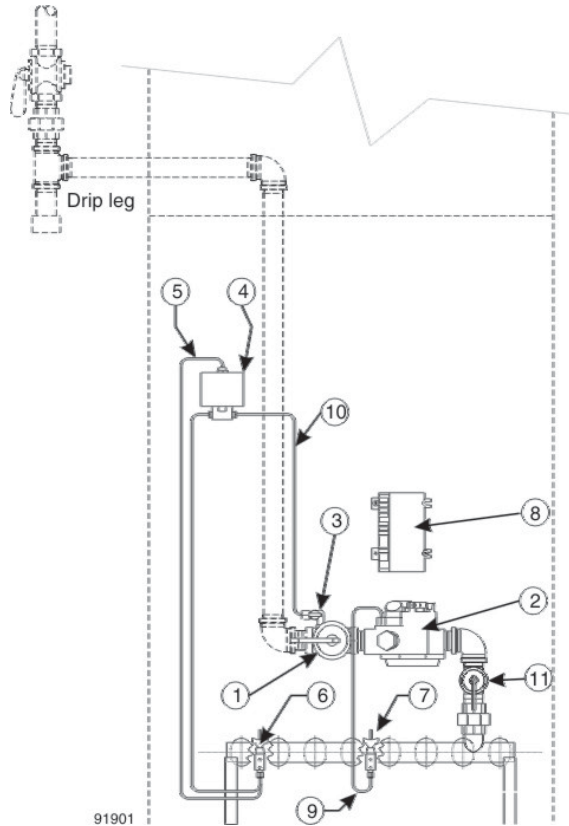

Ref. No.	Description	Vendor/Part Number	Weil-McLain Part Number
1	Hand valve – 1" NPT	Kinco-Balon 500 Conbraco #50-403-02	511-246-325
2	Gas valve – 1" NPT	Robertshaw 7000DERHC-S7C	511-044-279
3	Pilot shutoff valve	Kinco-Balon P2R	511-246-340
4	Pilot switch box	Johnson L62GB-3C	511-330-229
5	Thermocouple, 48" long	Honeywell Q309A	511-724-245
6	Standing pilot burner repair kit, propane	Weil-McLain	383-300-410
7	Electronic pilot burner, propane	Weil-McLain	511-330-222
8	Ignition control module	United Technologies 1003-511 Honeywell S862C1003	511-330-097
9	Pilot tubing, alum. 1/8" O.D. x 34" long	Available at Local Supply House	
10	Pilot tubing, alum. 1/4" O.D. x 0.32 – 60" long	Available at Local Supply House	
11	Manual test firing valve	Watts FBV3-06	511-246-290



Weil-McLain
500 Blaine Street
Michigan City, IN 46360-2388
<http://www.weil-mclain.com>