

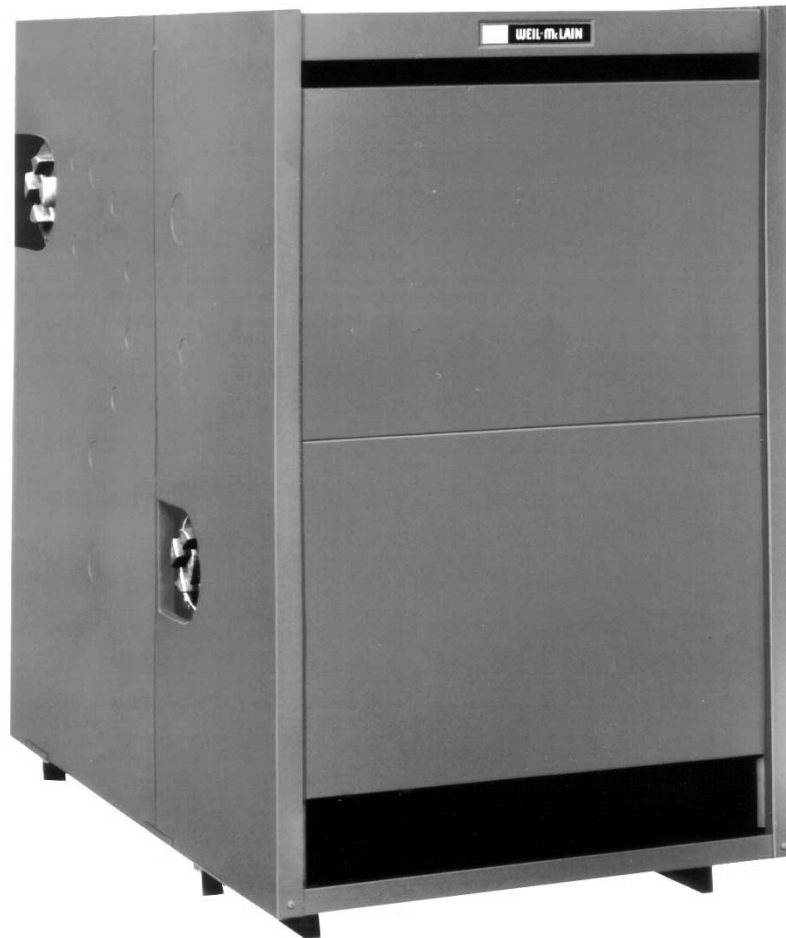

LGB *Gas-fired boiler*

Control Supplement

LGB-5 Series 2 – Natural gas
CSD-1 Control System





Please read this page first

Hazard definitions

The following terms are used throughout this Control Supplement to bring attention to the presence of hazards of various risk levels or to important information concerning the life of the product.

DANGER

Indicates presence of hazards that will cause severe personal injury, death or substantial property damage.

WARNING

Indicates presence of hazards that can cause severe personal injury, death or substantial property damage.

CAUTION

Indicates presence of hazards that will or can cause minor personal injury or property damage.

NOTICE

Indicates special instructions on installation, operation or maintenance that are important but not related to personal injury or property damage.

To the installer:

WARNING

This Control Supplement must only be used by a qualified installer/service technician. Read these instructions completely before beginning the installation. Failure to follow these instructions can cause severe personal injury, death or substantial property damage.

This Control Supplement is for CSD-1 controls on LGB-5 boilers only.

This document is only intended as a supplement to the **LGB Installation • Start-up • Service • Parts Manual** (referred to in this Supplement as the **LGB Manual**). Follow all instructions in the **LGB Manual** in addition to the instructions in this Control Supplement.

NOTICE

The installation must conform to the requirements of the authority having jurisdiction, or, in the absence of such requirements, to the National Fuel Gas Code, ANSI Z-223.1/NFPA-54 (latest edition). Where required by the authority having jurisdiction the installation must conform to the American Society of Mechanical Engineers (ASME) Safety Code for Controls and Safety Devices for Automatically-Fired Boilers, Number CSD-1.

Contents	A	Installation & boiler assembly	4
	B	Gas piping	6
	C	Water and steam trim components	7
	D	Wiring	8
		Wiring — sequence of operation	9
		Wiring diagrams & illustration	10–13
	E	Leak test procedure	14
	F	Operating instructions	16
	G	Replacement parts	18



Carton guide

Table 1 Boiler cartons

Verify that the correct cartons are available before beginning assembly.

Carton	Comments	Weil-McLain part number
Section assembly	Left end section	313-300-109
	Intermediate section (3)	313-300-110
	Right end section	313-300-111
Assembly parts box	A-5 box	383-300-004
Base assembly (b)	Base size 5	383-300-039
	End panel	383-300-165
Jacket	Standard LGB	413-300-001
	Carton LGB-5	413-300-011
Collector hood	Collector hood 5	450-019-859
Draft hood	Draft hood 5	443-300-099
Control carton (a)	LGB-5 CSD-1 Control carton, Natural gas	383-300-255
Trim cartons — water (c)	Basic trim	383-300-114
	Manual reset limit (L4006E-1000)	510-312-041
	M/R probe LWCO (PS-851M-120)	511-114-529
Trim cartons — gravity return steam (c)	Basic trim	383-300-135
	Manual reset limit (L404C-1147)	510-312-060
	Auto reset float LWCO (61)	511-114-474
	Manual reset float LWCO (63M)	511-114-479
Trim cartons — pumped return steam (c)	Basic trim	383-300-135
	Manual reset limit (L404C-1147)	510-312-060
	A/R float LWCO/pump control (150S-MD)	511-114-526
	Manual reset float LWCO (63M)	511-114-479
Note a	Control carton contains CSD-1 gas train, CSD-1 ignition control panel, transformer, J-box, and electronic pilot burner and mounting bracket.	
Note b	Base assembly includes burner tubes, gas orifices and burner manifold.	
Note c	Water Basic trim carton includes limit controls, relief valve, and pressure/temperature gauge. Steam Basic trim carton includes limit controls, relief valve, pressure gauge, and water gauge glass set and cocks.	



A Installation & boiler assembly

Place the boiler

Refer to the **LGB Manual** and read through entire manual. Follow all guidelines in Sections I through VI. Complete the following steps of Sections I through VI of the **LGB Manual** —

- I Pre-installation
- II Boiler assembly (base, sections, pressure test and flue collector hood)
- III Piping (boiler water or steam piping connections)
- IV Jacket
- V Draft hood
- VI Install boiler controls (refer to this Supplement for the controls supplied with CSD-1 boilers and requirements for installing them)

Install pilot burner assembly

1. Assemble bracket and pilot burner to main burner number 5 (from left side) as shown in Figures 1 and 2.
2. Connect 125 °C ground wire (provided in control carton) from pilot mounting bracket (per Figure 2) to the ignition control module grounding screw on the control panel (after ignition control panel is mounted per this Supplement).
3. Connect pilot spark and sense wires to the ignition control (terminals **SPARK** and **SENSE**) (after the ignition control panel is mounted per this Supplement).
4. Reinstall burner assembly. Make sure pilot is located in the position shown in Figure 1.

Figure 1

Pilot burner assembly
Locate pilot burner in 5th position from left, as shown.

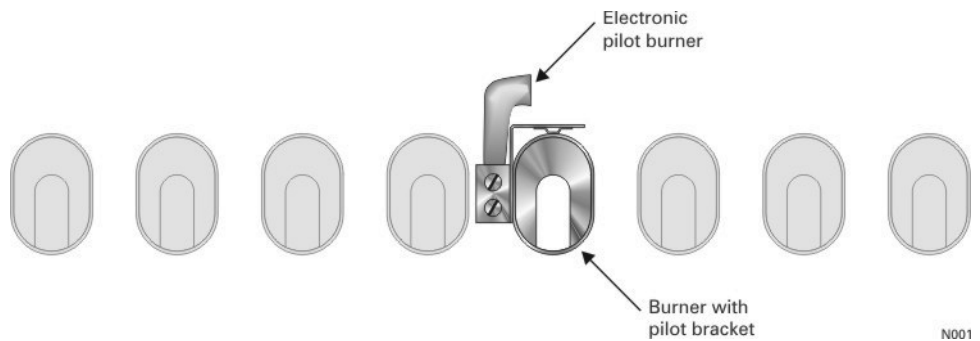
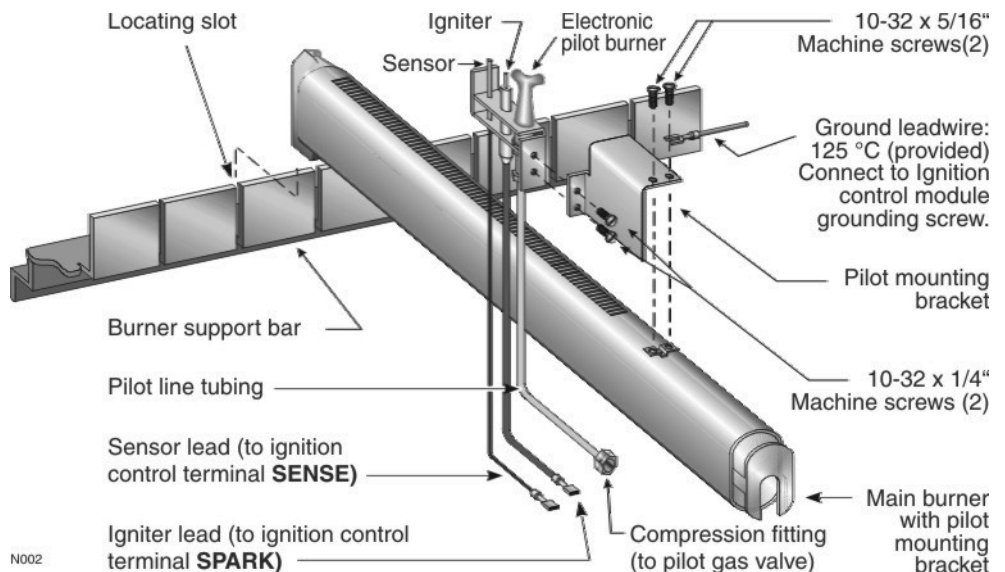

Figure 2

Electronic pilot burner assembly to main burner





A Installation – *continued*

Install gas train assembly

Connect gas train assembly to burner manifold by:

1. Apply pipe dope to burner manifold nipple (Figure 3, item 1).

WARNING

Pipe joint compound used must be resistant to corrosive action of liquefied petroleum gases. Apply sparingly only to male threads of pipe joints. Use of excessive pipe joint compound can result in damage and possible failure of gas train components.

2. Pipe lower half of gas train ground joint union to this nipple (Figure 3, item 2).
3. Knock out the gas valve opening on the left side of the boiler. The gas supply can only enter from the left because of the length of the gas train.
4. Place gas train in position and hand-tighten the ground joint union. Position the gas train assembly and tighten the union securely.
5. Connect vent lines (routed to outside per code requirements) to 1/4" tubing vent connections on main gas valve and pilot gas pressure regulator (Figure 3, item 3).
6. Connect pilot gas tubing (1/8" aluminum) to adapter in pilot gas valve outlet (Figure 3, item 4).
7. Crimp connect two 1/4" spade terminals to ends of pilot gas valve wires (Figure 3, item 5).

Figure 3
Gas train assembly

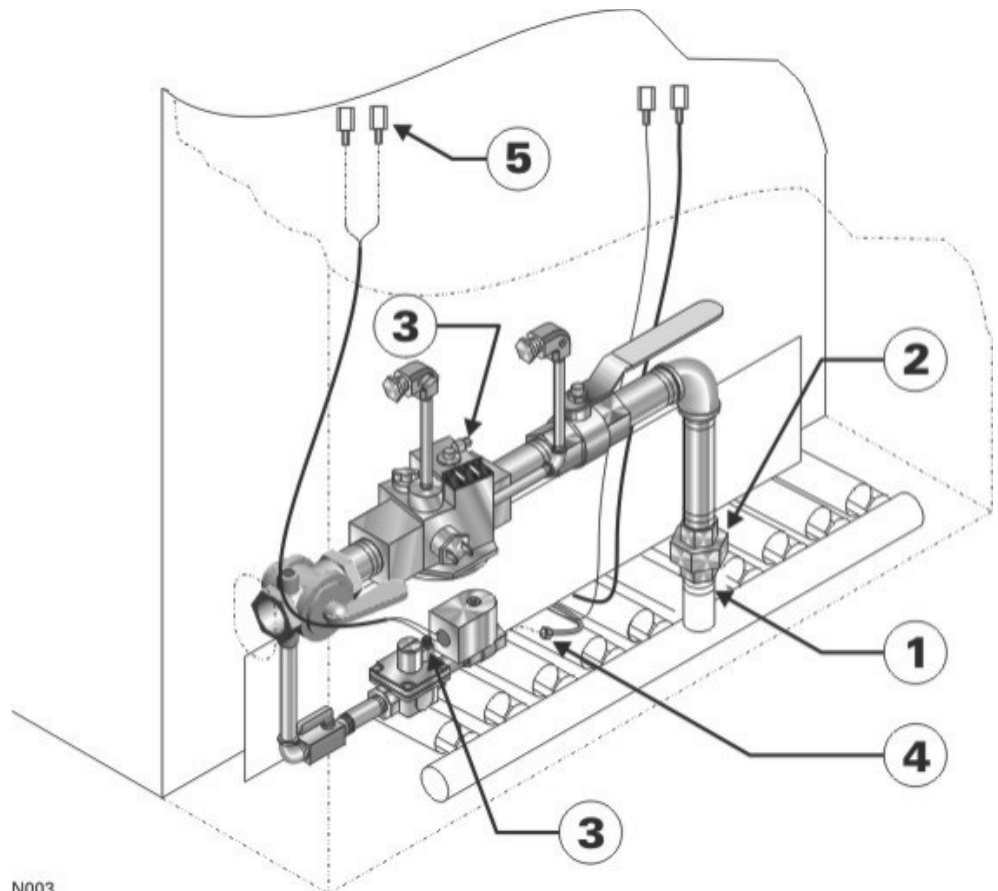

N003



B Gas piping

1. Size natural gas piping from Table 2, below. Size piping to provide proper inlet pressure to gas valve when operating at rated input.
 - a. Inlet gas pressure to manual main shutoff gas valve — minimum 5" W.C. — maximum 13" W.C.
 - b. If pressure to gas valve exceeds 13" W.C., install 100% lockup gas pressure regulator upstream of gas valve.
 - c. To obtain approximate cubic feet per hour, divide input (Btu/hr) by 1000.
2. Size gas piping considering:
 - a. Diameter and length of gas supply piping.
 - b. Number of fittings.
 - c. Maximum gas consumption (including any possible future expansion).
 - d. Allowable pressure drop from gas meter to boiler. For pressure drops, see ANSI Z223.1. – latest edition.
3. Follow good piping practices.

WARNING

Pipe joint compound used must be resistant to corrosive action of liquefied petroleum gases. Apply sparingly only to male threads of pipe joints. Use of excessive pipe joint compound can result in damage and possible failure of gas train components.

4. Install manual main gas valve and drip leg at inlet of gas connection to boiler. Where local code/utility requires, extend drip leg to floor.
5. Install ground joint union when required for servicing.
6. Support piping by hangers, not by boiler or its accessories.
7. Purge all air from supply piping.
8. Before operating boiler, check boiler and its gas connections for leaks.

WARNING

Do not check for gas leaks with an open flame — **BUBBLE TEST**. Failure to use bubble test or test for leaks can cause severe personal injury, death or substantial property damage.

- a. Close manual main gas valve during any pressure testing at less than 13" W.C.
- b. Disconnect boiler from gas supply piping during any pressure test greater than 13" W.C.



Table 2 — Gas pipe sizing — natural gas

Pipe size	*Pipe length, in feet (Natural Gas capacities listed in MBH) (Specific gravity 0.60 @ Pressure Loss of 0.30" W.C.)							
	10	20	30	40	50	75	100	150
1 ¼	1,050	730	590	500	440	360	305	250
1 ½	1,600	1,100	890	760	670	545	460	380
2	3,050	2,100	1,650	1,450	1,270	1,020	870	710
2 ½	4,800	3,300	2,700	2,300	2,000	1,650	1,400	1,130
3	8,500	5,900	4,700	4,100	3,600	2,900	2,500	2,000
4	17,500	12,000	9,700	8,300	7,400	6,000	5,100	4,100

*Include measured length of gas supply piping and allowance in feet for number and size of fittings.

C Water and steam trim components

1. LGB-5 CSD-1 boilers are equipped with the following components, as required by the ASME CSD-1. Consult local codes for any special or additional requirements.
 - a. LGB-5 CSD-1 water boilers include the following:
 - manual reset high temperature limit control.
 - automatic reset limit control.
 - manual reset low water cutoff (probe type). Install the probe low water cutoff in the supply or return piping, above the top of the boiler. The low water cutoff must be mounted between the boiler and any isolation valve(s) installed in the piping.
 - b. LGB-5 CSD-1 steam boilers include the following:
 - manual reset high pressure limit control.
 - automatic reset limit control.
 - manual reset low water cutoff (float type).
 - float type automatic reset low water cutoff (gravity return steam boilers)
 - or —
 - float type automatic reset low water cutoff/pump control (pumped return steam boilers).

NOTICE

The controls may be mounted on either end of the boiler. All controls (and the junction box) must be mounted on the same end.



D Wiring

WARNING

For your safety, turn off electrical power supply before making any electrical connections to avoid possible shock hazard.

WARNING

A strain relief bushing and adapter must be used at each point where wiring passes through the boiler jacket or control cases to protect wiring insulation.

NOTICE

The boiler limit controls and low water cutoff(s) are exterior to the boiler jacket, and must be wired per N.E.C. class 1 in conduit. The wire (No. 14 gauge or heavier) and conduit for these controls is supplied by the installer — it is not included with the boiler.

Assembly illustration and wiring diagrams

This Supplement contains a schematic and ladder wiring diagram.

The diagrams show limit control and low water cutoff connections for both water and steam boilers.

See Figure 5, pages 12 and 13 for a typical finished assembly.

General

Refer to **LGB Manual** for further information.

All wiring must be installed in accordance with the requirements of the National Electrical Code and any additional national, state or local code requirements having jurisdiction. All line voltage wiring external to boiler jacket must be N.E.C. class 1.

Provide a separate electrical circuit with a fused disconnect switch (15 amp recommended) to supply the boiler. Wiring to the boiler must be No. 14 gauge or heavier, installed in conduit.

The boiler must be electrically grounded in accordance with the National Electrical Code, ANSI/NFPA No. 70, latest edition.

Use 105 °C thermoplastic wire, or equivalent, if any original wire must be replaced (except for pilot spark and sense wires and 125 °C pilot burner ground wire).

Wiring procedure

1. Mount all controls as directed in Section C of this Supplement. Refer to the assembly illustration, Figure 5, page 12 for component locations.
2. Mount the junction box supplied with the boiler on the inside left (or right) side of the jacket as shown in the assembly illustration (using screws and nuts provided). The junction box must be mounted on the same end of the boiler as the controls will be mounted.
3. Attach the transformer/relay to the junction box.
4. Mount the CSD-1 control panel on the jacket interior panel as shown in the assembly illustration, Figure 5, page 12 (using screws and nuts provided).
5. Crimp connect ¼" spade terminals (provided) to the pilot gas valve wires (if not already done in Section A of this Supplement). Connect the pilot valve black wire to the ignition control **PV** terminal. Connect the pilot valve white wire to the main gas valve **TR** terminal.
6. Connect pilot burner ground wire, spark wire and sense wire to ignition control as directed in wiring diagram and Figure 2, page 4.
7. The main gas valve wires are pre-attached to the CSD-1 control panel. Connect these wires as shown in the wiring diagram.
8. Use minimum 14-gauge thermoplastic wire (105 °C or better), supplied by installer, to complete wiring of the remaining components according to the appropriate wiring diagram and the assembly illustration. Route all wiring to external components (limit controls and low water cutoffs) in conduit per N.E.C. class 1.



D Wiring — sequence of operation

General

The following sequence of operation applies to all wiring covered by this Supplement — both water and steam.

Call for heat

On a call for heat (from thermostat or operating control):

1. Limit control and water level control contacts are assumed closed.
2. Ignition control checks for signal at pilot. (No signal should be present.)

If no signal is sensed (normal condition):

- a. Pilot solenoid opens.
- b. Pilot ignition spark begins.
- c. Pilot ignites.
- d. Pilot proves.

If a signal is sensed (abnormal condition), the control will lockout.

NOTICE

On failure to establish pilot flame signal within 15 seconds, the ignition control will turn off the pilot gas valve. It will wait 5 minutes, then retry for ignition. If the second ignition attempt fails, the ignition control will lockout and illuminate the red lockout light.

NOTICE

This will activate the alarm contact of the impulse relay, providing an isolated contact closure across terminals A1 and A2 of the CSD-1 control panel terminal strip. The contact rating is 15 amps at 250 VAC.

To reset the boiler, push the red reset button on the CSD-1 control panel.

3. Once pilot is proved the ignition control activates main gas valve. Main burners will ignite and boiler will continue to fire until terminated by limit action or no call for heat.

Lockout modes

In addition to lockout on flame-sense failure, the boiler may also experience lockout due to shutdown of a manual reset control.

NOTICE

The boiler is equipped with a manual reset limit control and a manual reset low water cutoff. Should the limit control or the low water cutoff lockout, the boiler will only restart after the limit control or low water cutoff reset switch is pressed.

CAUTION

Steam boilers — Do not substitute another manual reset low water cutoff for the one specified and supplied with the boiler. Other controls may not operate as intended and could cause serious operating problems or failures.



D Wiring — diagrams

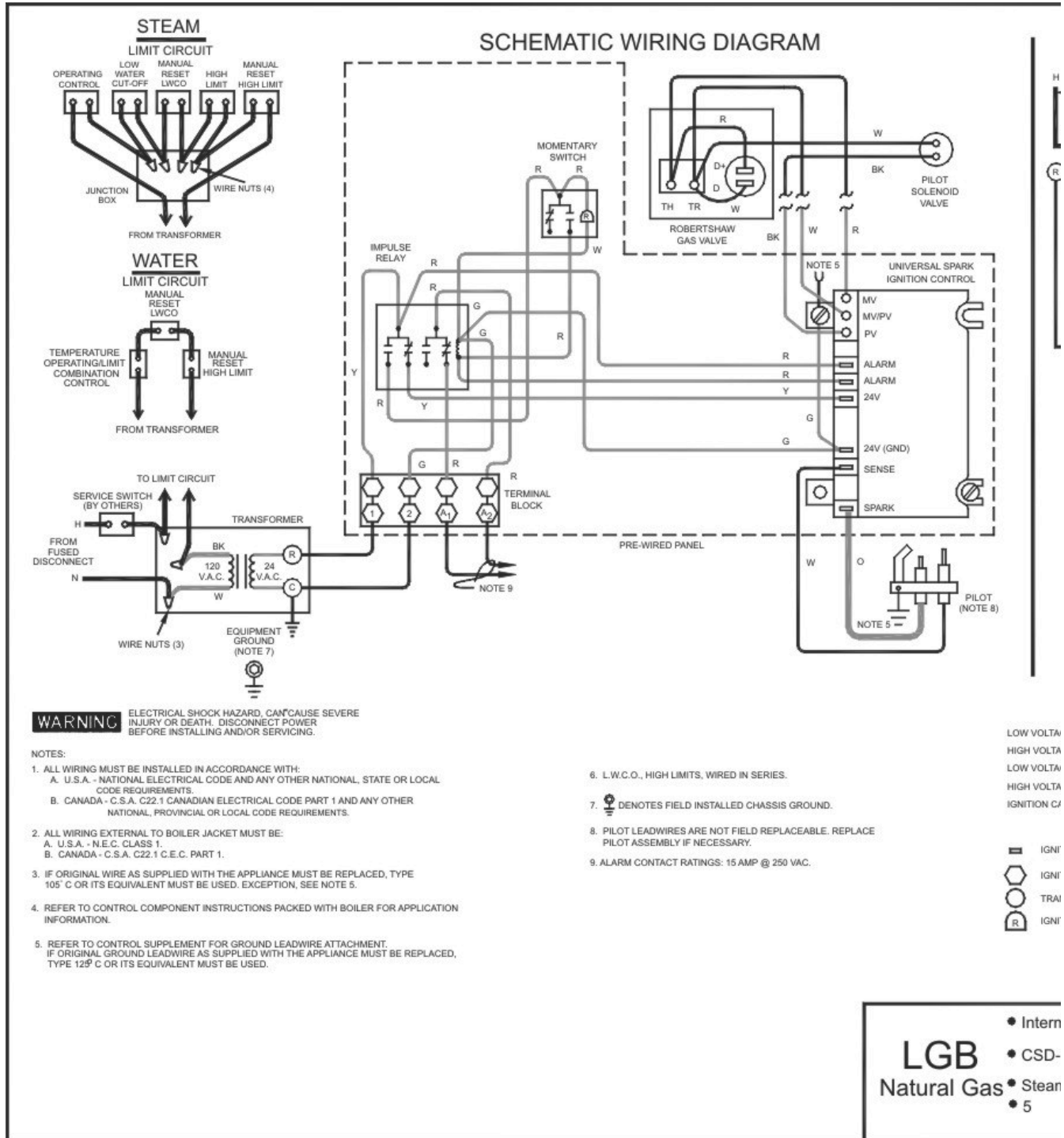

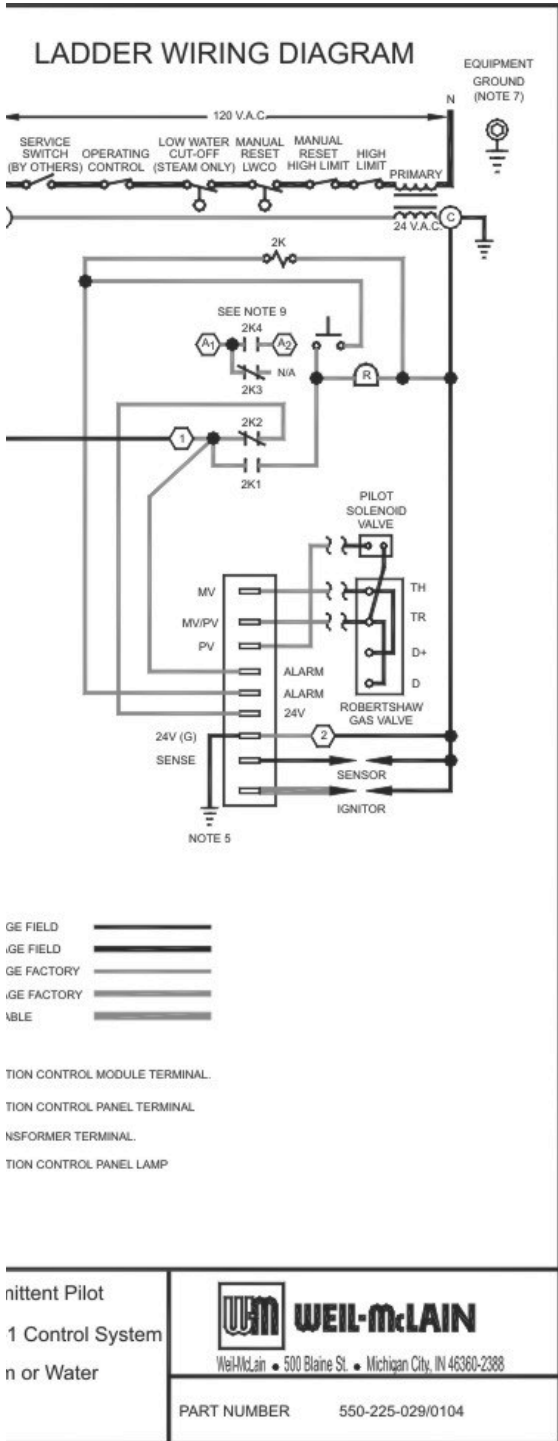

Figure 4

Ladder and schematic wiring diagrams



1	CSD-1 control panel	11	Leak test valves with plugs
2	Ignition control	12	Gas supply connection
3	Impulse relay and lighted push-button alarm silencing switch	13	Burner manifold
4	Terminal strip	14	Pilot spark & sense wires
5	Transformer	15	Pilot gas tubing
6	Junction box	16	Probe LWCO, manual reset
7	Main gas valve	17	Limit control, auto reset
8	Manual gas valve	18	Limit control, manual reset
9	Pilot gas valve	19	Pressure/temperature gauge
9a	Pilot gas pressure regulator	20	Hand gas valve
10	Pilot shutoff valve		

LGB-5 CSD-1 Series 2 Natural gas — Control Supplement



E Leak test procedure

WARNING

For your safety, turn off electrical power supply before making any electrical connections to avoid possible shock hazard.

1. Turn off power to the boiler and remove the (RED) wire from terminal TH of the main gas valve (Figure 6, item 1). Tape off terminal end of removed wire and restore power to the boiler.
2. Open hand gas valve (Figure 6, item 7). Close manual gas valve (Figure 6, item 2).
3. Check that both leak test valves (Figure 6, items 3 and 4) are closed. Then remove plugs and insert 1/8" NPT hose barb fittings as shown in Figure 6.
4. Attach a U-tube manometer to first leak test valve (Figure 6, item 3).
5. Open first leak test valve (Figure 6, item 3) and check for pressure. See NOTICE below.
6. Close first leak test valve (Figure 6, item 3) and remove manometer.
7. Attach manometer to second leak test valve (Figure 6, item 4).
8. Apply call for heat to boiler and check that electronic pilot proves.
9. Open second leak test valve (Figure 6, item 4) and check for pressure. See NOTICE below.
10. Close second leak test valve and remove manometer.
11. Remove call for heat to boiler. Turn off power to the boiler.
12. Remove hose barbs from leak test valves and replace plugs.
13. Replace (RED) wire to terminal TH of gas valve.
14. Open manual gas valve (Figure 6, item 2) and restore power to boiler.

NOTICE

When checking for pressure at the leak test valves, it is normal to find a small pressure reading. If the pressure continues to rise after opening the leak test valve, the main valve seat is leaking and should be replaced.



Figure 6
Gas train assembly

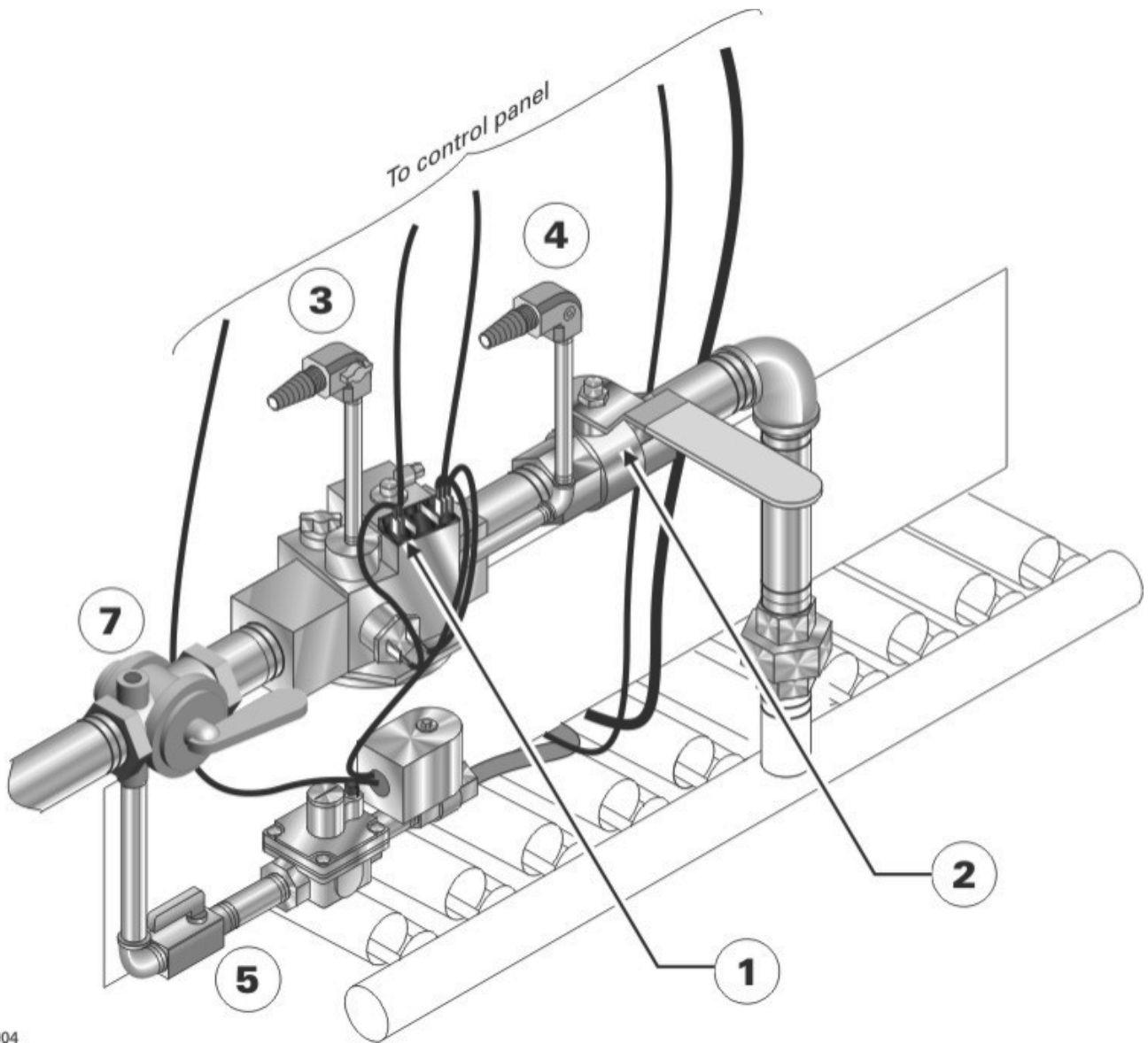

N004



F Operating instructions

WARNING

- A. This boiler is equipped with an ignition device which automatically lights the pilot. Do not try to light the pilot by hand.
- B. BEFORE OPERATING THE MANUAL PILOT, smell all around the appliance area for gas. Be sure to smell next to the floor because some gas is heavier than air and will settle on the floor.

WHAT TO DO IF YOU SMELL GAS

- Do not try to light any appliance.
 - Do not touch any electric switch; do not use any phone in your building.
 - Immediately call your gas supplier from a neighbor’s phone. Follow the gas supplier’s instructions.
 - If you cannot reach your gas supplier, call the fire department.
- C. Do not use this appliance if any part has been under water. Immediately call a qualified service technician to inspect the appliance and to replace any part of the control system and any gas control, which has been under water.

WARNING

This document is intended only as a supplement to the **LGB Manual**. Follow all instructions in the **LGB Manual**, including those regarding final adjustment and boiler operation and maintenance (found in Sections VII, VIII, IX and X).

Figure 7
Gas train assembly

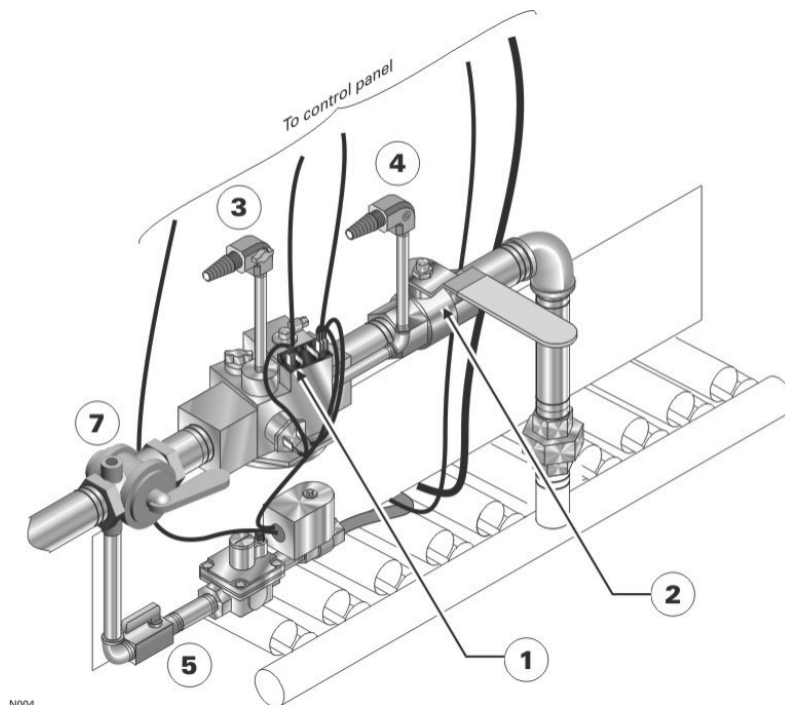



Starting the boiler

1. STOP! Read the safety information on opposite page.
2. Set the **operating control** to lowest setting.
3. Turn off all electrical power to the appliance.
4. Remove boiler **front jacket panel**.
5. This appliance is equipped with an ignition device which automatically lights the pilot. Do not try to light the pilot by hand.
6. Close the **pilot shutoff valve** (Figure 7, item 5). Open **hand gas valve** (Figure 7, item 7). Close the **manual gas valve** (Figure 7, item 2).
7. Wait five (5) minutes to clear out any gas. Then smell for gas, including near the floor. If you smell gas, **STOP!** Follow “**B**” in the safety information on the opposite page. If you don’t smell gas, go to the next step.
8. Verify **ignition control** operation on flame failure:
 - a. **Pilot shutoff valve** and **manual gas valve** should both be closed.
 - b. Turn on electric power to the boiler.
 - c. The **ignition control** will initiate spark, attempting to light the pilot.
 - d. After 15 seconds the **ignition control** should shut down (no flame sensed). The **ignition control** should then wait approximately 5 minutes, then attempt once again to ignite the pilot.
 - e. With no gas available, the **ignition control** will be unable to light the pilot. After 15 seconds of ignition attempt, the control should shut down and lockout due to flame failure.
 - f. If the **ignition control** performs correctly, turn off the electric power to the boiler and proceed to step 9. If the **ignition control** does not operate correctly, skip to step 10.
9. Proceed with boiler start-up:
 - a. Open the **pilot shutoff valve** (Figure 7, item 5).
 - b. Open the **manual gas valve** (Figure 7, item 2).
 - c. Turn on electric power to the boiler.
 - d. Set **operating control** to desired setting.
 - e. The boiler should operate correctly. If so, proceed to step 11 and skip step 10.
10. If the appliance will not operate:
 - a. Turn off gas to the boiler by closing the **manual gas valve** (Figure 7, item 2). Also close the **pilot shutoff valve** (Figure 7, item 5).
 - b. Turn off all electric power to the boiler.
 - c. Call your **service technician** or **gas supplier**.
11. Replace boiler **front jacket panel**.



G Replacement parts

Figure 8 — Boiler assembly, typical

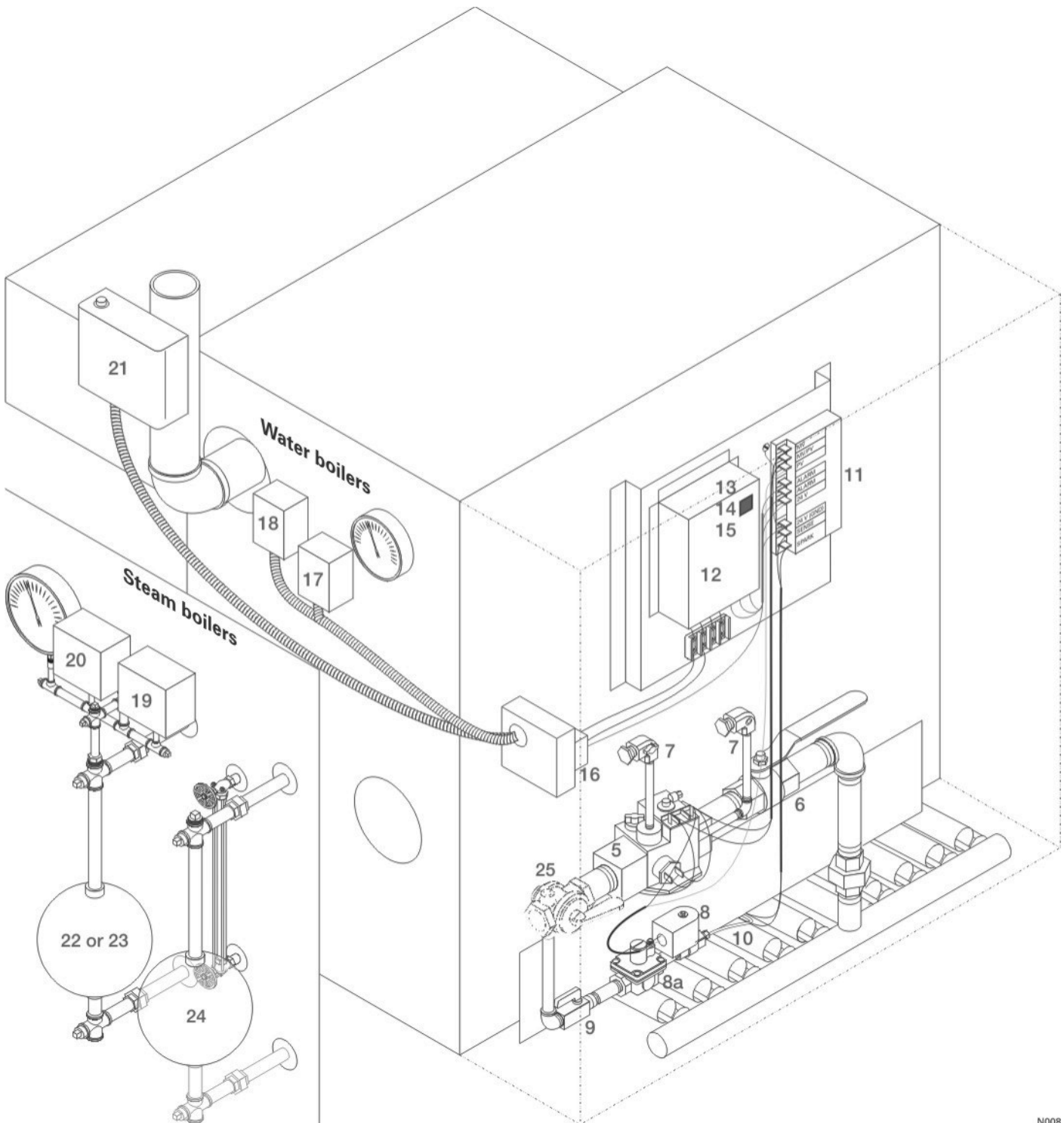

N008



Table 3 — Boiler replacement parts

Item	Part description	Vendor	Vendor part number	Weil-McLain part number
1	Pilot burner	Weil-McLain		511-330-218
5	Main gas valve	Robertshaw	7000DERHC-S7C	511-044-279
6	Manual gas valve, 1" NPT	Watts	FBV3-06	511-246-290
7	Leak test valve	Key Gas		511-246-339
8	Pilot gas valve	Honeywell	V8046C-1014	511-044-039
		Johnson Controls	H91ABG	
8a	Pilot gas pressure regulator	Maxitrol	RV20VL	510-933-195
9	Pilot shutoff valve	Conbraco	53-300-01	511-246-345
10	Pilot tubing, alum. 1/8" O.D. x 34" long	Available at local supply house		
11	Ignition control	United Technologies	1003-615	511-330-086
12	Impulse relay	Potter-Brumfield	S89R-11ABD1-24	510-350-226
13	Push-button switch	Honeywell	AML21CBA2AA	511-624-580
		Eaton Controls	221K11810	
14	Lens cover (push-button switch)	Honeywell	AML51-C10R	511-624-581
		Eaton Controls	220PM02A	
15	Light bulb (push-button switch)	T1-¾ (available at local supply house)		
16	Transformer, 120vac/24vac, 75 va	Honeywell	AT175C-1004	511-842-364
		Johnson Controls	Y66ACD-1C	
17	Temperature limit control, automatic reset	Johnson Controls or Honeywell		510-312-209
18	Temperature limit control, manual reset	Honeywell	L4006E-1000	510-312-041
19	Pressure limit control, automatic reset	Johnson Controls	PA404A-1009	510-312-135
20	Pressure limit control, manual reset	Honeywell	L404C-1147	510-312-060
21	Probe LWCO, manual reset	McDonnell & Miller	PS851M-120	511-114-528
22	Float LWCO, automatic reset	McDonnell & Miller	61	511-114-494
23	Float LWCO/pump control, auto reset	McDonnell & Miller	150S-MD	511-114-526
24	Float LWCO, manual reset	McDonnell & Miller	63M	511-114-479
25	Hand gas valve	Weil-McLain		511-246-326

Replacement parts must be purchased through a local Weil-McLain distributor. When ordering, specify boiler model and series and include description and number of replacement part. Results from using modified or other manufactured parts will not be covered by warranty and may damage boiler or impair operation.

Refer to illustrations and instructions in this **Supplement** for component locations.

Refer to LGB manual for parts not listed above.



Weil-McLain
500 Blaine Street
Michigan City, IN 46360-2388
<http://www.weil-mclain.com>