

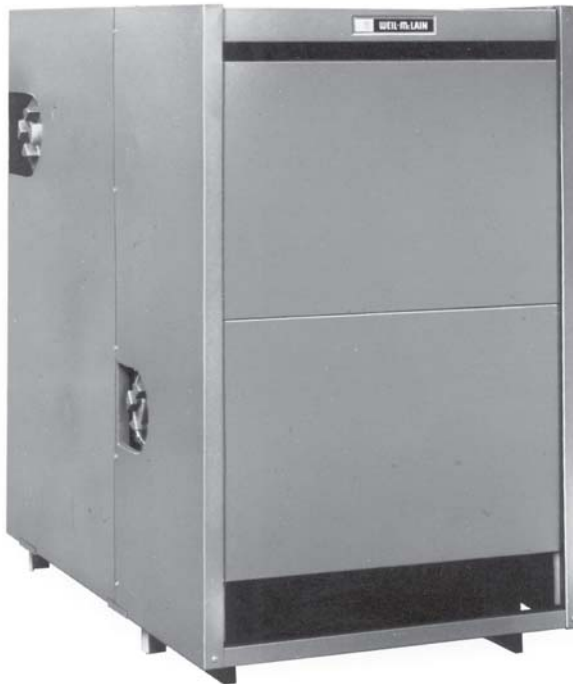

LGB *Gas-fired boiler*

Control Supplement

LGB-6 to LGB-23 Series 2 – Propane gas Universal Control System



Contents

- I. New installation 2
- II. Existing installation 4
- III. Gas piping 5
- IV. Wiring 5
 - Sequence of operation 8
 - Wiring procedure 8
- V. Operating instructions . 9
- VI. Verification testing.... 10
- VII. Parts list 11

These terms are used throughout this manual to bring attention to the presence of hazards of various risk levels or to important information concerning the life of the product.

WARNING

Indicates presence of hazards that can cause severe personal injury, death or substantial property damage.

NOTICE

Indicates special instructions on installation, operation or maintenance that are important but not related to personal injury or property damage.

WARNING

This Control Supplement must only be used by a qualified installer/service technician. Read these instructions completely before beginning the installation. Failure to follow these instructions can cause severe personal injury, death or substantial property damage.



I New installation

1. Remove all burners from base box assembly. Remove 3.95 mm natural gas main burner orifices in manifold. Install 2.40 mm propane gas main burner orifices. Use pipe dope sparingly only on male ends. Use pipe dope compatible with propane gases. Do not overtighten orifices.
2. Install pilot burners and flame sensor(s). See Figures 1 and 2 (page 3). Follow Table 1 for electronic pilot burner (UCS), standing pilot burner (Q327) and flame sensor locations on manifold.
3. Install gas controls and ignition control panel as shown in Table 2, below and Figure 5 on page 10.
4. Attach pilot switch box to interior jacket panel. See Figure 5 on page 10. Connect thermocouple from standing pilot to switch box. Cut 60" pilot tubing into 2 pieces to make connections from pilot valve to pilot switch box and from pilot switch box to standing pilot.
5. LGB-21 through LGB-23 require High Gas Pressure Switch Control Carton furnished with boilers. Attach pressure switch to interior jacket panel. See Figure 5 (page 10) or Figure 6 (page 11).
6. Attach:
 - a. 550-223-710 label above or to the left of boiler operating instruction label. Place so that this label reads first.
 - b. 550-223-796 label next to rating label.
 - c. Wiring diagram on door (one on each base).
 - d. Canada only - mount rating plate on interior jacket panel.

Table 1

Pilot burner and flame sensor locations

Boiler Model Number	Flame Sensor*		Electronic Pilot Burner*		Standing Pilot Burner*		Boiler Model Number	Flame Sensor*		Electronic Pilot Burner*		Standing Pilot Burner*	
	No. 1	No. 2	No. 1	No. 2	No. 1	No. 2		No. 1	No. 2	No. 1	No. 2	No. 1	No. 2
LGB-6	2	--	9	--	6	--	LGB-15	2	16	13	27	8	22
LGB-7	2	--	11	--	7	--	LGB-16	2	18	15	29	9	24
LGB-8	2	--	13	--	8	--	LGB-17	2	18	15	31	9	25
LGB-9	2	--	15	--	9	--	LGB-18	2	20	16	33	9	27
LGB-10	2	--	16	--	9	--	LGB-19	2	20	16	34	9	27
LGB-11	2	--	16	--	9	--	LGB-20	2	22	16	36	9	29
LGB-12	2	--	16	--	9	--	LGB-21	2	22	16	36	9	29
LGB-13	2	14	11	23	7	19	LGB-22	2	24	16	38	9	31
LGB-14	2	16	13	25	8	21	LGB-23	2	24	16	38	9	31

* From left burner

Table 2

Gas control arrangement

Boiler Model Number	Propane Carton	Inlet Pipe Size		Boiler Model Number	Propane Carton	Inlet Pipe Size	
		Left base	Right base			Left base	Right base
LGB-6	A and B	1"	--	LGB-15	J	1"	1"
LGB-7	A and B	1"	--	LGB-16	J	1"	1"
LGB-8	C and D	1"	--	LGB-17	J	1"	1"
LGB-9	C and D	1"	--	LGB-18	K	1 ¼"	1"
LGB-10	E, F and G	1 ¼"	--	LGB-19	L	1 ¼"	1 ¼"
LGB-11	E, F and G	1 ¼"	--	LGB-20	L	1 ¼"	1 ¼"
LGB-12	E, F and G	1 ¼"	--	LGB-21	L	1 ¼"	1 ¼"
LGB-13	H	1"	1"	LGB-22	L	1 ¼"	1 ¼"
LGB-14	I	1"	1"	LGB-23	L	1 ¼"	1 ¼"



I New installation – continued

Figure 1

Pilot burner assembly, typical

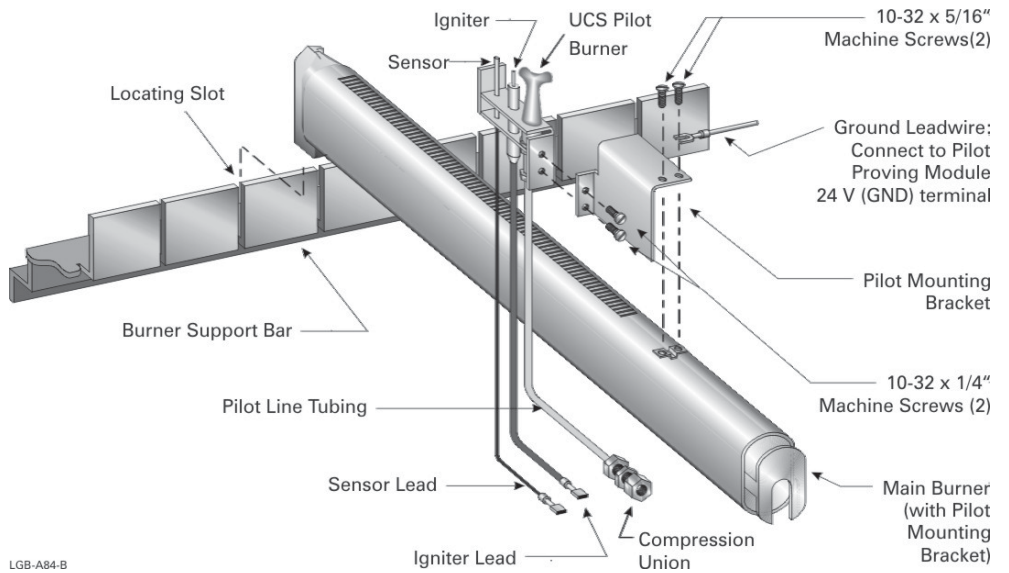

LGB-A84-B

Figure 2

Main flame sensor assembly

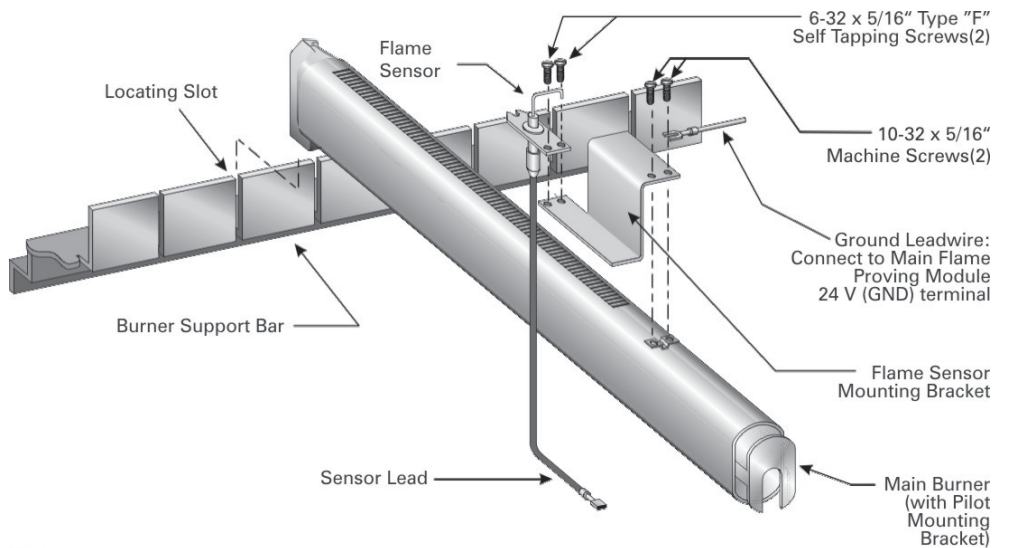

LGB-A85



II

Existing installation Conversion from natural gas to propane gas

WARNING

This conversion is to be installed by a Weil-McLain distributor or other qualified agency in accordance with the manufacturer's instructions and all codes and requirements of the authority having jurisdiction. Failure to follow instructions could result in serious injury or property damage. The qualified agency performing this work assumes responsibility for this conversion.

WARNING

For your safety, turn off electrical power supply before making any electrical connections to avoid possible electrical shock hazard.

1. These instructions are for use with Propane Control Cartons as listed in Gas Control Arrangement, Table 2 (page 2).
2. Remove jacket door(s) and access panel(s).
3. Disconnect wiring and tubing from existing pilot burner and main flame sensor.
4. Remove all burners. Remove 3.95 mm natural gas main burner orifices in manifold. Install 2.40 mm propane gas main burner orifices. Use pipe dope sparingly only on male ends. Use pipe dope compatible with propane gases. Do not overtighten orifices.
5. Remove and discard existing electronic pilot burner from pilot burner tube. Replace with electronic pilot burner in carton.
6. Attach Q327 standing pilot to burner tube in kit. Connect pilot tubing and thermocouple to pilot.
7. Re-install burners. See Table 1 (page 2) for location of pilot burners and flame sensor(s).
8. Attach pilot switch box to jacket. See Figure 5 on page 10. Connect thermocouple to pilot switch box. Cut 60" pilot tubing into 2 pieces to make connections from tee in pilot line to pilot switch box and from pilot switch box to standing pilot.
9. Remove natural gas valve train.
10. Install propane gas valve train and fittings from carton (See page 5, section III, paragraph 4 of this Supplement).
11. Re-install access panel(s).
12. See Figure 5 on page 10 for propane piping.
13. Wire per wiring diagram, Figure 3 (pages 6 and 7). Add splices as needed.
14. Attach:
 - a. 550-223-710 label above or to the left of boiler operating instruction label. Place so that this label reads first.
 - b. 550-223-796 label next to rating label.
 - c. Wiring diagram over diagram on door (one on each base).
15. To place in operation, follow instructions on constant burner pilot light-up label and boiler operating label.
16. Replace jacket doors.



III Gas piping

1. Contact gas supplier to size pipes, tanks and regulator.
 - a. Inlet gas pressure to manual main shut-off gas valve — minimum 11" W.C., maximum 13" W.C.
 - b. If pressure to gas valve exceeds 13" W.C., install 100% lock-up gas pressure regulator upstream of hand valve.
2. Remove gas supply knockout disc from jacket panel.
3. Follow good piping practices.
4. Pipe joint compound (pipe dope) must be resistant to corrosive action of liquefied petroleum gases. Apply sparingly only to male threads of pipe joints.
5. Install drip leg at inlet of gas connection to boiler. Where local utility requires, extend drip leg to floor.
6. Install ground joint union when required for servicing.
7. Support piping by hangers, not by boiler or its accessories.
8. Purge all air from supply piping.
9. Before operating boiler, check boiler and its gas connections for leaks.

WARNING

Do not check for gas leaks with an open flame – BUBBLE TEST. Failure to use bubble test or test for leaks can cause severe personal injury, death or substantial property damage.

- a. Close manual main shut-off valve during any pressure testing at less than 13" W.C.
 - b. Disconnect boiler and gas valve from gas supply piping during any pressure test greater than 13" W.C.
10. Set gas pressure switch as follows or to local inspector's requirements (LGB-21 through LGB-23 only):
 - a. High – 14" W.C.
11. Canada only - manual main shut-off valve must be identified by installer.

IV Wiring

WARNING

For your safety, turn off electrical power supply before making any electrical connections to avoid possible electrical shock hazard.

1. All wiring must be installed in accordance with the requirements of the National Electrical Code and any additional national, state or local code requirements having jurisdiction. All wiring must be N.E.C. Class 1.
2. The boiler must be electrically grounded in accordance with the National Electrical Code, ANSI/NFPA No. 70-latest edition. Use 105 °C. thermoplastic wire, or equivalent, if any of the original wire must be replaced (except for pilot spark, sense and ground wires).
3. Canadian installations must conform to CSA C22.1 Canadian Electrical Code Part 1 and any local or provincial codes.
4. Supply wiring to the boiler must be No. 14 gauge or heavier. Install in conduit.
5. A separate electrical circuit with a fused disconnect switch (15 amp. recommended) should be used for the boiler.



IV Wiring – continued

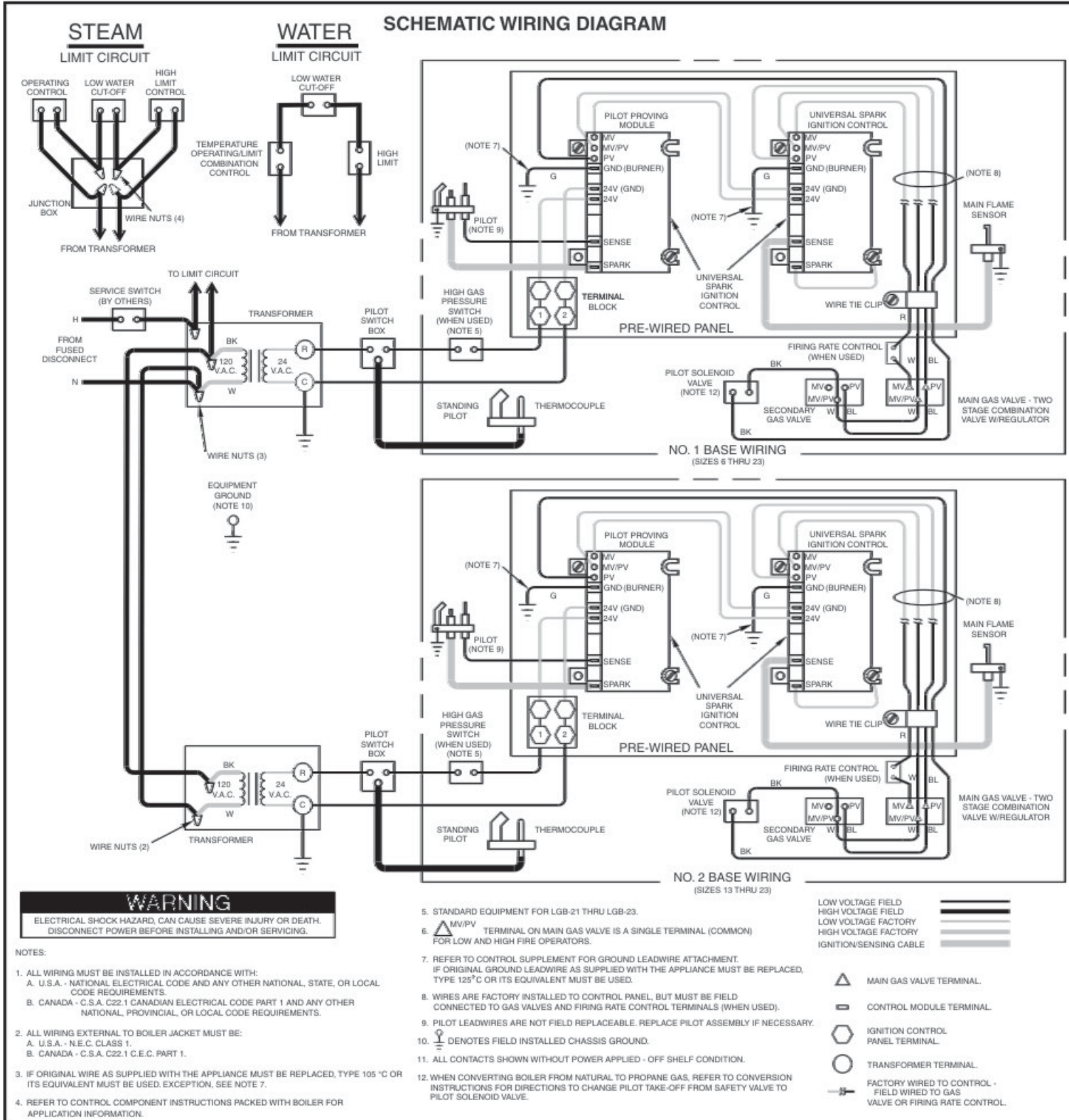

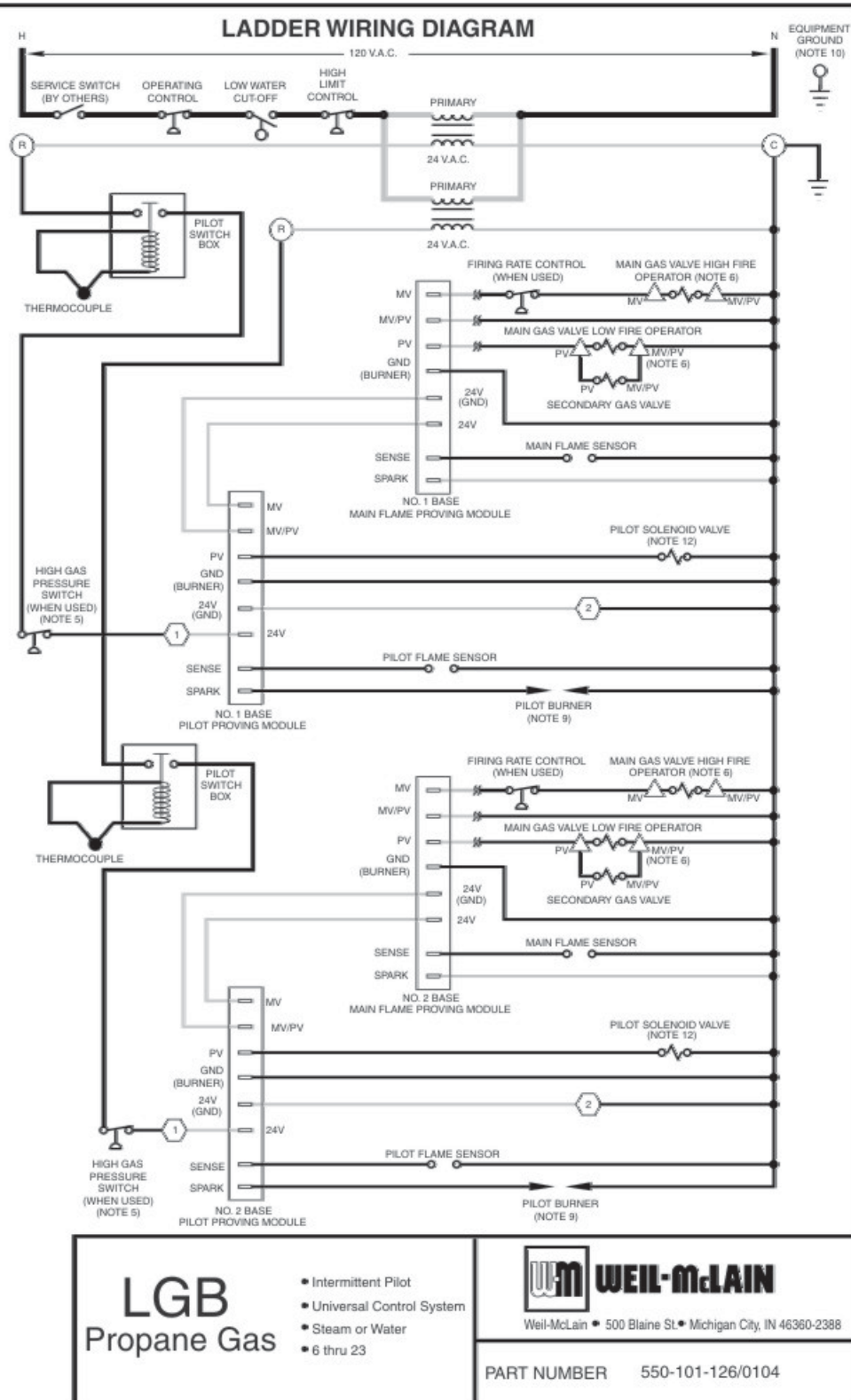

Figure 3
Wiring diagram



IV

Wiring – continued

Sequence of operation

1. Operating control begins start-up sequence.
 - a. Limit control contacts are closed.
2. Pilot-proving module energized.

NOTICE On failure to sense pilot flame or main flame, control will wait 5 minutes then retry for ignition.

 - a. Pilot solenoid opens.
 - b. Pilot ignition spark begins.
 - c. Pilot ignites.
 - d. Pilot proves.
3. Main flame-proving module energized from pilot-proving module.
 - a. Secondary gas valve opens.
 - b. Main gas valve opens to low fire position.
 - c. Main burners ignite at low fire.
 - d. Main flame sensor proves low fire carryover.
 - e. Main gas valve opens to high fire position.
 - f. Main burners increase to high fire.
4. Dual base assembly (LGB-13 through LGB-23) - operating control energizes the controls for both base assemblies at the same time. See steps 1 through 3 above.
5. Boiler shuts down when the operating control is satisfied.

Wiring Procedure

1. Determine right or left electrical supply wiring.
2. Attach electrical junction box(es) to inside jacket end panel. Screws and nuts are provided. For dual base boilers, use offset nipples (provided) to connect junction boxes together, then hang junction boxes by screwing top box to boiler jacket. See Figure 4.
3. Attach control transformer(s) to junction box(es).
4. Drill 1/8" hole in interior jacket panel midway between ignition control panel and left jacket panel. Mount wire support clip using sheet metal screw (furnished).
5. Complete wiring per wiring diagram, Figure 3, pages 6 and 7. Terminate at secondary gas valve in valve junction box with wirenuts and strain relief provided.

NOTICE “Hot” side of line voltage to boiler must be wired directly to limit circuit, then fed to transformer primary(ies). Dual Base: “R” terminal of secondaries are to supply power to bases independently of each other. Do not wire “R” terminals together.

6. Install pilot proving and main flame proving ground connections as shown in Figures 1, 2 and 3. Route wires through wire support clip.
7. Canada only - attach chain between junction box(es) and transformer with S-hooks.

Figure 4

Junction box assembly
dual base boilers

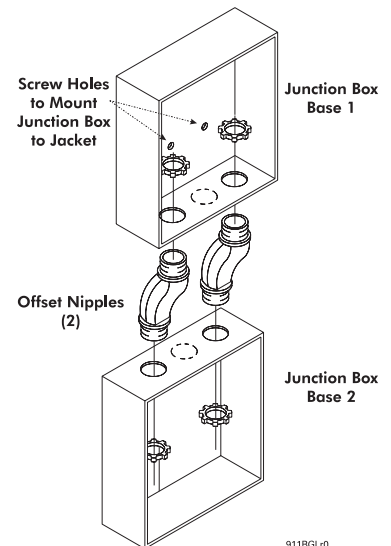



IV Operating instructions

FOR YOUR SAFETY READ BEFORE OPERATING

WARNING

If you do not follow these instructions exactly, a fire or explosion may result causing property damage, personal injury or loss of life.

- A. This appliance is equipped with an ignition device which automatically lights the pilot. Do not try to light the automatic pilot by hand. For PROPANE BOILERS ONLY: Propane boilers contain both an automatic pilot and a manual (standing) pilot. A pilot switch box controls gas flow to the manual pilot. Follow instructions below to manually light the manual pilot. Do not try to light the automatic pilot by hand.
- B. Before OPERATING, smell all around the appliance area for gas. Be sure to smell next to the floor because some gas is heavier than air and will settle on the floor. See below.
- C. Use only your hand to depress or turn gas valve handles. Never use tools. If a handle will not turn by hand, don't try to repair it. Call a qualified service technician. Force or attempted repair may result in a fire or explosion.
- D. Do not use this appliance if any part has been under water. Immediately call a qualified service technician to inspect the appliance and to replace any part of the control system and any gas control, which has been under water.

WHAT TO DO IF YOU SMELL GAS

- Do not try to light any appliance.
- Do not touch any electric switch; do not use any phone in your building.
- Immediately call your gas supplier from a neighbor's phone. Follow the gas supplier's instructions.
- If you cannot reach your gas supplier, call the fire department.

OPERATING INSTRUCTIONS

1. STOP! Read the safety information above this label.
2. Set the thermostat/operating control to the lowest setting.
3. Turn off all electrical power to the appliance.
4. Remove jacket front panel. On PROPANE BOILERS ONLY: Remove base access shield.
5. Close gas hand valve, **b**. Close manual test firing valve, **c**. Close all pilot shutoff valve(s), **g**.
6. Wait five (5) minutes to clear out any gas. Then smell for gas, including near the floor. If you smell gas, STOP! Follow **B** in the safety information above. If you do not smell gas, go to step 7.
7. Open pilot shutoff valve(s), **g**.
8. On PROPANE BOILERS ONLY:
 - Press and hold reset lever of pilot switch box, **d**.
 - Manually light manual pilot, **e**, while holding the lever down.
 - Allow time for air to purge from the pilot line. Release lever after pilot flame has had time to heat thermocouple (about 1 minute). Pilot burner should remain lit.
9. Open manual test firing valve, **c**, and gas hand valve, **b**. Follow sequence below.
10. Turn on electric power to the appliance.
11. Set the thermostat/operating control to desired setting.
12. If boiler does not operate correctly, follow instructions under, "TO TURN OFF GAS TO APPLIANCE," below. Call your service technician or gas supplier.
13. On PROPANE BOILERS ONLY: Replace base access shield.
14. Replace jacket front panel.

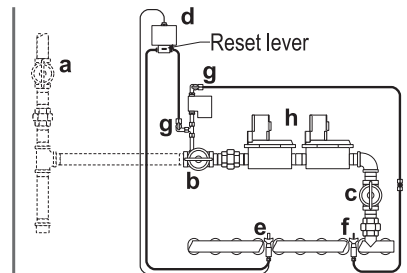

Typical gas piping only — See Control Supplement for details

- a service valve
- b gas hand valve
- c manual test firing valve
- d pilot switch box (propane only)
- e manual pilot (propane only)
- f automatic pilot
- g pilot shutoff valve(s)
- h automatic gas valves, typical

TO TURN OFF GAS TO THE APPLIANCE

1. Set thermostat or operating control to lowest setting.
2. Turn off all electrical power to the appliance if service is to be performed.
3. Close manual test firing valve (**c**), all pilot shutoff valve(s) (**g**) and gas hand valve (**b**).
4. Replace base access shield (on PROPANE BOILERS ONLY) and jacket front panel.

550-223-000(1001)



VI

Verification testing

WARNING

Before starting boiler for the first time and at least annually (during annual inspection and start-up), follow the procedures below to verify boiler controls are operating correctly and that automatic gas valve properly shuts off gas flow. Failure to verify boiler operation could result in severe personal injury, death or substantial property damage.

Manual test firing valve

This boiler is equipped with a manual test firing valve — the manual gas valve piped between the gas manifold and the first automatic gas valve in the gas train. Closing the manual test firing valve allows verification of proper boiler operation without allowing gas flow to the manifold and allows leak testing of the automatic gas valves. Follow the procedures below.

Verify boiler control sequence

1. Follow the Operating Instructions in this Supplement to start the boiler, but **do not open the manual test firing valve**. Open all other manual gas valves as instructed. Leave the manual test firing valve closed.
2. The automatic pilot burner should light.
3. After the pilot lights, the boiler controls should activate the automatic gas valves. Use a voltmeter to verify voltage to automatic valves.
4. With no gas flow to the manifold, the boiler ignition controls should turn off the automatic gas valves after main flame ignition trial. Use a voltmeter to verify voltage to automatic valves is turned off.

Leak test automatic gas valve

1. Close manual test firing valve.
2. Open the service valve and gas hand valve.
3. Install a hose barb into a pressure tap downstream of the first automatic gas valve. Allow any accumulated gas in the line to vent off. Then connect a U-tube manometer. If the valve seals properly, there should be no gas pressure present. Remove manometer and hose barb and replace pipe plug in pressure tap.
4. Connect the manometer downstream of the second automatic gas valve. Temporarily remove the power leads to the first automatic gas valve. Then connect 24 volt power to the first automatic gas valve terminals to open it. If the second valve seals properly, there should be no pressure at the manometer.
5. Remove the temporary power supply to the automatic gas valve. Reconnect its power leads. Remove the manometer and plug any open pressure taps.
6. Follow Operating Instructions to place boiler in service.

WARNING

Replace any defective components. Do not attempt to operate boiler or leave boiler in operation if any component is found to be defective or to operate incorrectly. Failure to comply could result in severe personal injury, death, or substantial property damage.



VII

Parts list – continued

Figure 5
Parts
drawing

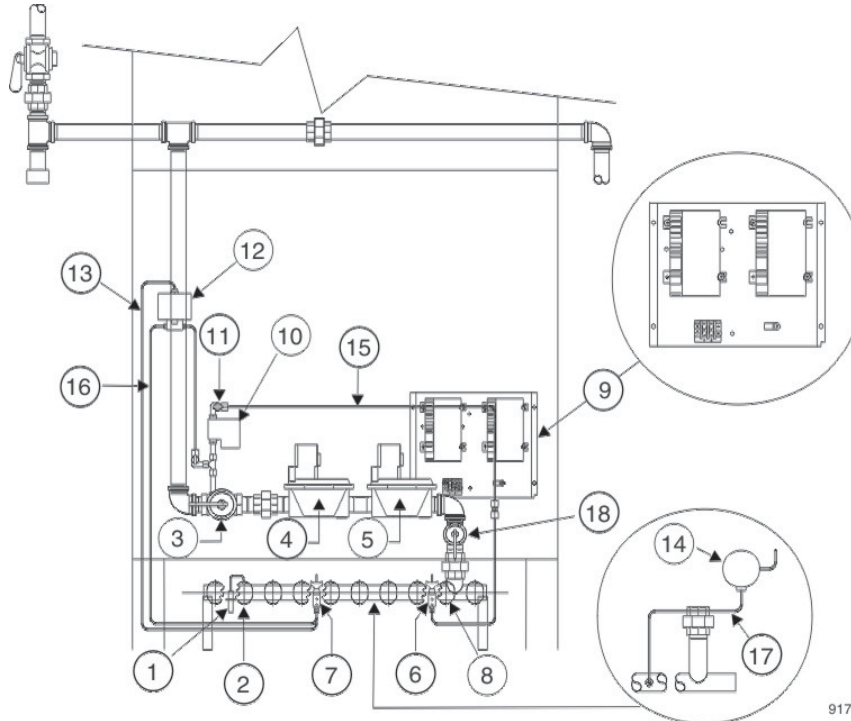

91701

Ref. No.	Description	Size	Vendor/Part Number	Weil-McLain Part Number
1	Main flame sensor		Honeywell 392956	511-724-274
2	Main burner with pilot bracket Main flame sensor bracket		Weil-McLain	512-200-055 423-300-420
3	Manual main shut-off valve	1" 1¼"	Kinco-Balon 500 Kinco-Balon 600	511-246-325 511-246-330
4	Secondary gas valve	1" 1¼"	Honeywell V8943A1103 Honeywell V8943A1111	511-044-191 511-044-192
5	Main gas valve	1" 1¼"	Honeywell V8944L1033 Honeywell V8944L1041	511-044-346 511-044-218
6	Pilot burner, standing-repair kit propane		Weil-McLain	383-300-410
7	Pilot burner, electronic-repair kit propane		Weil-McLain	383-300-411
8	Main burner with pilot bracket Pilot burner bracket		Weil-McLain	512-200-055 460-005-624
9	UCS control module (2 per control panel)		Honeywell S8620C1003 United Technologies 1003-511	511-330-097
10	Pilot solenoid		Honeywell V8046C1014 Johnson Controls H91ABG	511-044-039
11	Pilot shut-off valve		Kinco-Balon P2R	511-246-340
12	Pilot switch box		Johnson Controls L62GB-3C	511-330-229
13	Thermocouple	48"	Honeywell Q309A	511-724-245
14	High gas pressure switch		Honeywell C645B1013	511-624-555
15	Pilot tubing, alum. ¼ O.D. x .032-20" long		Available at Local Supply House	
16	Pilot tubing, alum. ¼ O.D. x .032-60" long		Available at Local Supply House	
17	Pressure switch tubing, alum. ¼ O.D. x .032-100" long		Available at Local Supply House	
18	Manual test firing valve	1" 1¼" 1½"	Watts FBV3-06 Watts FBV3-07 Watts FBV3-08	511-246-290 511-246-292 511-246-294

*Contact local Weil-McLain distributor/agent for current replacement part and order number.



Weil-McLain
500 Blaine Street
Michigan City, IN 46360-2388
<http://www.weil-mclain.com>