

# LGB

*Gas-fired boiler*

## Control Supplement

### Flame Guardian WMBC-2A RM7895C Controller Electronic Pilot System IRI.....FM-HR.....CSD-1



<b>Contents</b>	
Installation .....	2
Gas piping .....	4
Wiring .....	5
Startup.....	9
Water & Steam trim.....	10
Sequence of Operation.....	10
Parts list.....	11



These terms are used throughout this manual to bring attention to the presence of hazards of various risk levels or to important information concerning the life of the product.

**WARNING**

Indicates presence of hazards that can cause severe personal injury, death or substantial property damage.

**NOTICE**

Indicates special instructions on installation, operation or maintenance that are important but not related to personal injury or property damage.

**WARNING**

This Control Supplement must only be used by a qualified installer/service technician. Read these instructions completely before beginning the installation. Failure to follow these instructions can cause severe personal injury, death or substantial property damage.



# Installation

1. For use with LGB-5 through 12 boilers.
2. LOCAL INSPECTOR MUST CERTIFY BOILER FOR IRI COMPLIANCE.
3. Assemble pilot burner and flame sensor to main burners with pilot brackets. See Figures 2 and 3. Install ground wiring as shown in Figures 2 and 3.
4. Reinstall burner assemblies. See Table 1 for pilot burner and flame sensor locations.
5. Assemble control panel to boiler. See Figure 1.
6. Install gas controls as shown in Figure 4, page 4.
7. IRI installations require manual reset controls. Weil-McLain recommends installing manual controls in addition to standard as required by local inspector. Refer to the LGB Boiler Manual, “Boiler Controls” section.
  - a. Steam boilers require a manual reset Low Water Cutoff and manual reset Pressure Limit Control.
  - b. Water boilers require a manual reset Low Water Cutoff and manual reset Temperature Limit Control.

**Figure 1**

Mount control panel jacket as shown

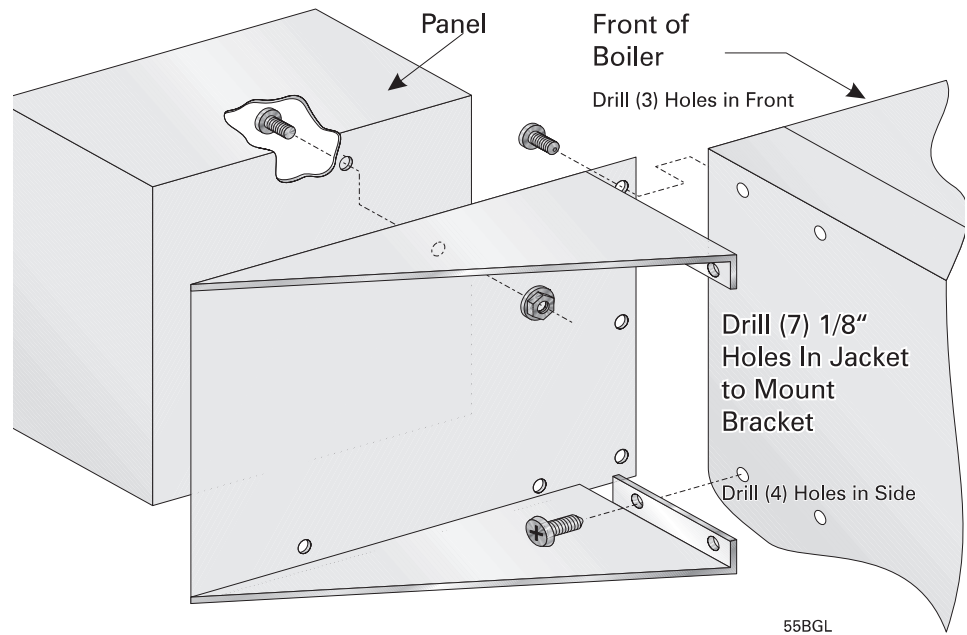

**Figure 2**

Q179 pilot burner assembly

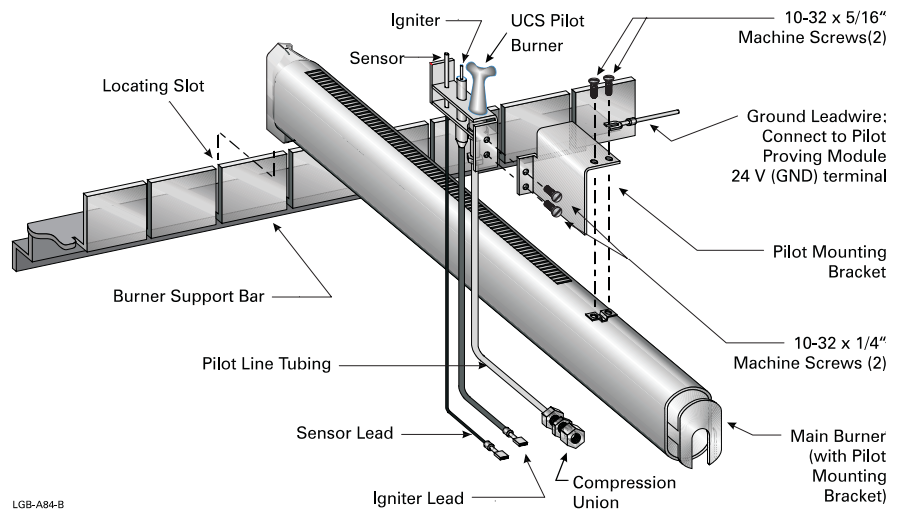



## Installation – continued

**Table 1**

Pilot burner and flame sensor locations

Boiler Number	Flame Sensor *		Pilot Burner *		Boiler Number	Flame Sensor *		Pilot Burner *	
	No. 1	No. 2	No. 1	No. 2		No. 1	No. 2	No. 1	No. 2
LGB-13	2		11	23	LGB-19	2		16	34
LGB-14	2		13	25	LGB-20	2		16	36
LGB-15	2		13	27	LGB-21	2		16	36
LGB-16	2		15	29	LGB-22	2		16	38
LGB-17	2		15	31	LGB-23	2		16	38
LGB-18	2		16	33					

\* From left burner.

**Figure 3**

Pilot burner number 2 – UCS pilot burner assembly

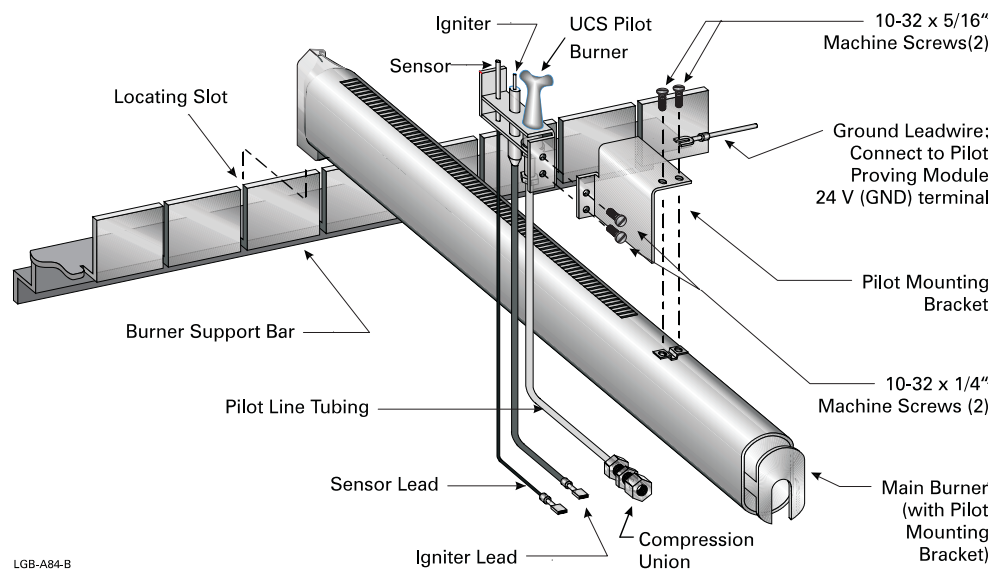

LGB-A84-B

**Figure 4**

Main flame sensor assembly

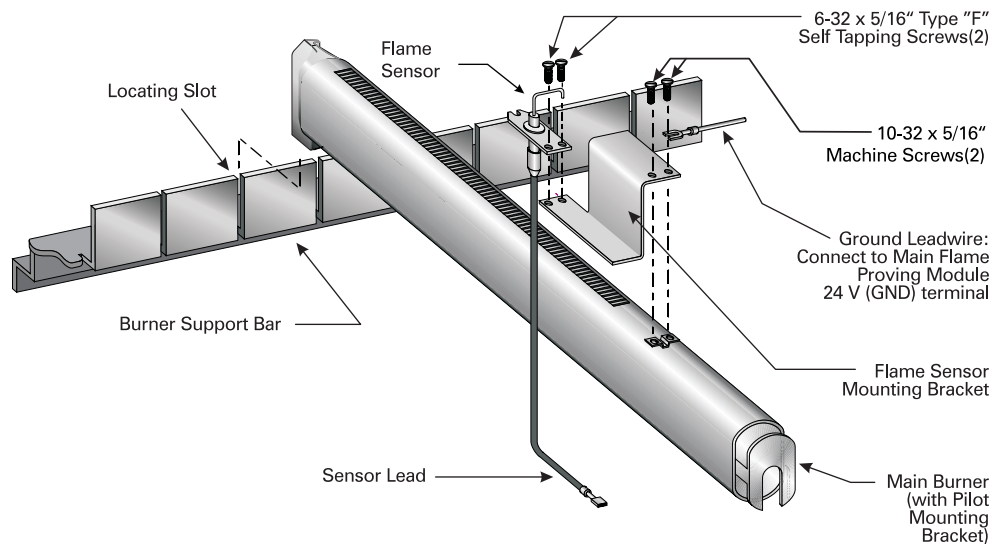

LGB-A85



# Installation – continued

**Figure 5** IRI - FM and CSD-1 gas train schematic

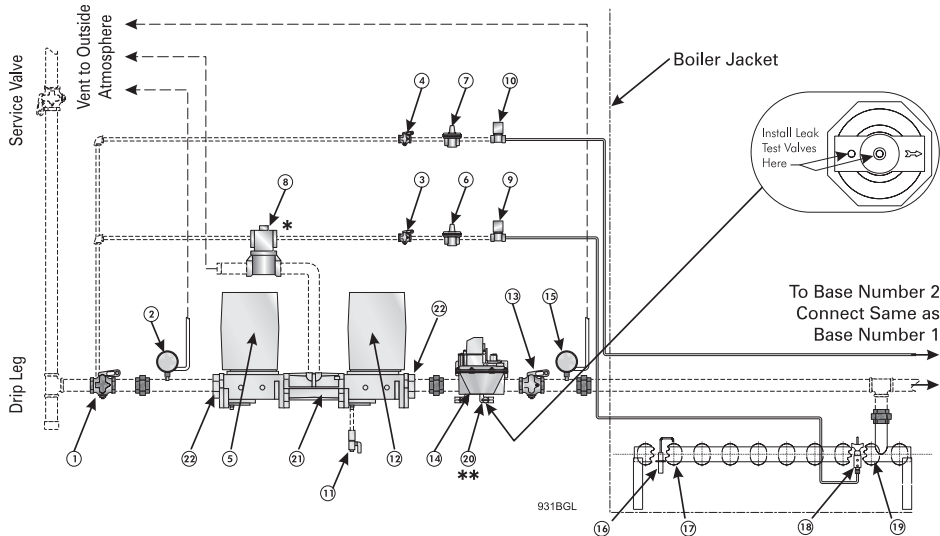

## GAS PIPING DIAGRAM - LGB (Series 2)

### IRI - FM Hi Risk - CSD-1

- |                                          |                                                  |
|------------------------------------------|--------------------------------------------------|
| 1 Manual main shut-off gas valve         | 12 Second motorized gas valve w/ on/off actuator |
| 2 Low gas pressure switch                | 13 Manual leak checking gas valve                |
| 3 No.1 pilot manual shut-off valve       | 14 Regulating diaphragm gas valve (two stage)    |
| 4 No. 2 pilot manual shut-off valve      | 15 High gas pressure switch                      |
| 5 Motorized gas valve w/ on/off actuator | 16 Main flame sensor                             |
| 6 No. 1 pilot gas pressure regulator     | 17 Main burner with main flame sensor bracket    |
| 7 No. 2 pilot gas pressure regulator     | 18 Pilot burner                                  |
| 8 Normally open solenoid vent valve*     | 19 Main burner with pilot burner bracket         |
| 9 No. 1 pilot solenoid gas valve         | 20 Test cock for CSD-1 only**                    |
| 10 No. 2 pilot solenoid gas valve        | 21 Adapter, for N. O. vent valve*                |
| 11 Test cock                             | 22 Pipe flanges                                  |

\* Required for IRI only

\*\* Required for CSD-1 only (LGB-21 thru LGB-23)

## Gas piping

- Size gas piping considering —
  - Diameter and length of gas supply piping.
  - Number of fittings.
  - Maximum gas consumption (including any possible future expansion).
  - Allowable pressure drop from gas meter to boiler. For pressure drops, see ANSI Z223.1. – latest edition.
- Size natural gas piping from Table 3, below. Size piping to provide proper inlet pressure to gas valve when operating at rated input.
  - Inlet gas pressure to manual main shut-off gas valve minimum 7" W.C. standard (5" W.C. on special order) – maximum 13" W.C.
  - If pressure to gas valve exceeds 13" W.C., install 100% lock-up gas pressure regulator upstream of hand valve.
  - To obtain approximate cubic feet per hour, divide input (Btu/hr) by 1000.
- Remove knockout disc from jacket panel through which gas supply will be piped.
- Follow good piping practices.



## Gas piping – continued

5. Pipe joint compound (pipe dope) must be resistant to corrosive action of liquefied petroleum gases. Apply sparingly only to male ends of pipe joints.
6. Install drip leg at inlet of gas connection to boiler. Where local code/utility requires, extend drip leg to floor.
7. Install ground joint union when required for servicing.
8. Support piping by hangers, not by boiler or its accessories.
9. Purge all air from supply piping.
10. Before operating boiler, check boiler and its gas connections for leaks.
  - a. Close manual main shut-off valve during any pressure testing at less than 13” W.C.
  - b. Disconnect boiler and gas valve from gas supply piping during any pressure test greater than 13” W.C.

**▲WARNING** Do not check for gas leaks with an open flame – BUBBLE TEST. Failure to use bubble test or test for leaks can cause severe personal injury, death or substantial property damage.

11. Set gas pressure switches as follows or to local inspector’s requirements:
  - a. Low – 3.0” W.C.
  - b. High – 14.0” W.C

**Table 2**

Gas pipe sizing - natural gas

Pipe size	*Pipe length, in feet (Natural Gas capacities listed in MBH)							
	(Specific gravity 0.60 @ Pressure Loss of 0.30" W.C.)							
	10	20	30	40	50	75	100	150
1-¼"	1,050	730	590	500	440	360	305	250
1-½"	1,600	1,100	890	760	670	545	460	380
2"	3,050	2,100	1,650	1,450	1,270	1,020	870	710
2-½"	4,800	3,300	2,700	2,300	2,000	1,650	1,400	1,130
3"	8,500	5,900	4,700	4,100	3,600	2,900	2,500	2,000
4"	17,500	12,000	9,700	8,300	7,400	6,000	5,100	4,100

\*Include measured length of gas supply piping and allowance in feet for number and size of fittings.

## Wiring

**▲WARNING** For your safety, turn off electrical power supply before making any electrical connections to avoid possible electrical shock hazard.

1. All wiring must be installed in accordance with the requirements of the National Electrical Code and any additional national, state or local code requirements having jurisdiction. All wiring external to boiler jacket must be N.E.C. Class 1.
2. The boiler must be electrically grounded in accordance with the National Electrical Code, ANSI/NFPA No. 70-latest edition. Use 105 °C thermoplastic wire, or equivalent, if any original wire must be replaced (except for pilot spark, sense and ground wires).
3. Wiring to boiler must be No. 14 gauge or heavier. Install in conduit.
4. A separate electrical circuit with a fused disconnect switch (15 amp. recommended) should be used for the boiler.
5. Use the high temperature 18 gauge, wire provided to spirally wrap the spark wire and main sense wire as per the following instructions. This spiraled wire will help shield components from electrical noise.
6. Strip 1” insulation from one end of the 18 gauge wire. Loosen one of the pilot assembly mounting screws, wrap the stripped bare end of the wire around the pilot mounting screw and re-tighten pilot assembly mounting screw. Then in a spiral mode, wrap the high temperature wire around the spark wire of the pilot assembly all the way back to the spark generator. Cut the 18 gauge wire and strip 1” insulation from this end. Loose one of the spark generator mounting screws, wrap the bare end of the wire around the screw and re-tighten the spark generator mounting screw.
7. With the remaining 18 gauge wire, strip 1” insulation from one end. Loosen one of the main flame sensor mounting screws, wrap the stripped bare end around the screw and re-tighten the main flame sensor mounting screw. Then in a spiral mode, wrap the high temperature wire around the main flame sensor wire all the way back to the main flame sensor connection in the WMBC control panel. Cut wire to appropriate length to connect to the G1 terminal in the WMBC control panel. Strip 1” insulation from the end of the wire. Loosen the G1 terminal screw, wrap the bare end of the wire around the screw and re-tighten the G1 terminal screw.



Figure 6 WMBC-2A Panel wiring diagram

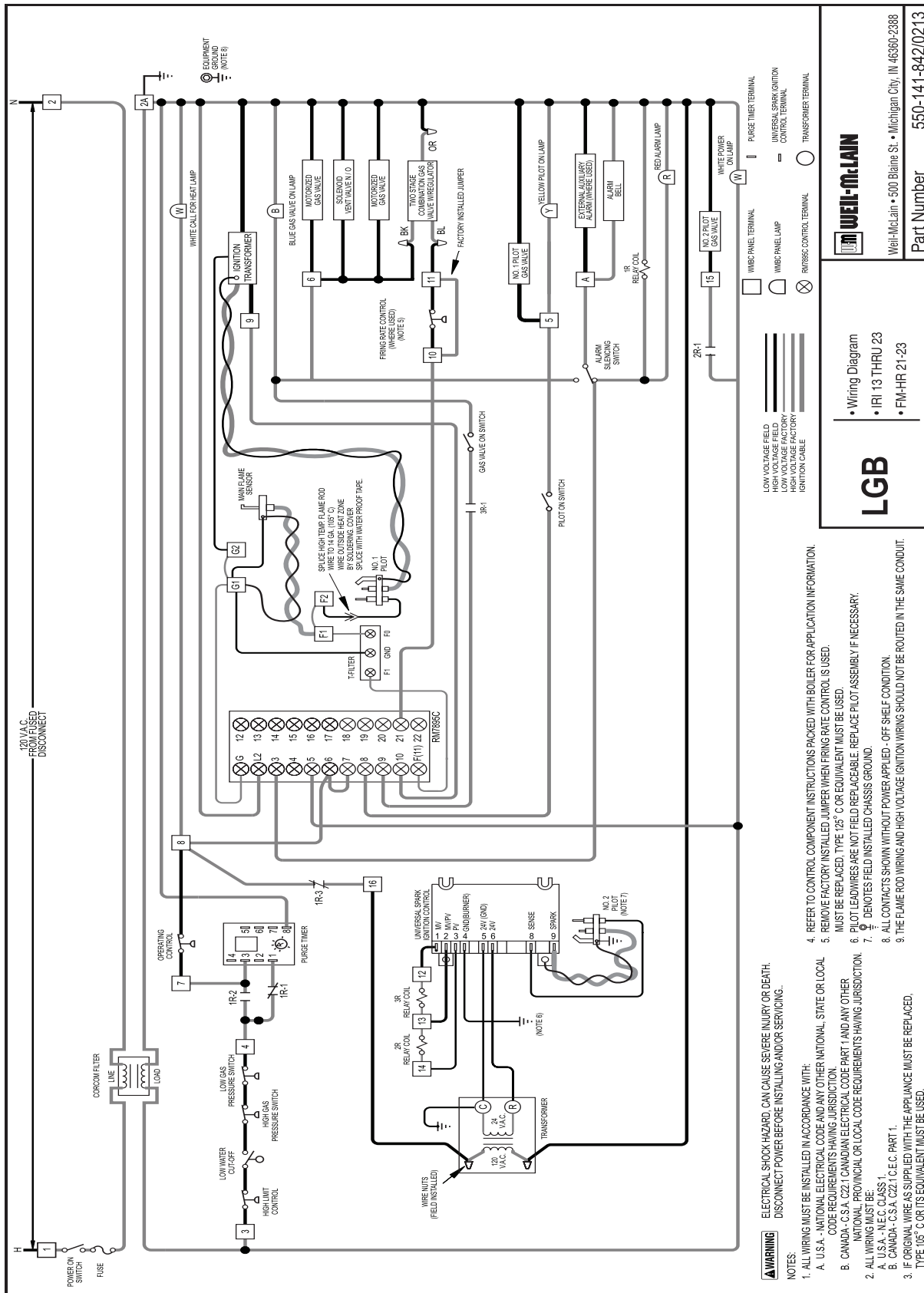

**WEIL-MCLAIN**

Well-McLain • 500 Blaine St. • Michigan City, IN 46360-2388

Part Number 550-141-842/0213

**LGB**

- Wiring Diagram
- IRI 13 THRU 23
- FM-HR 21-23



**Figure 7** WMBC-2A Panel wiring diagram – factory wiring

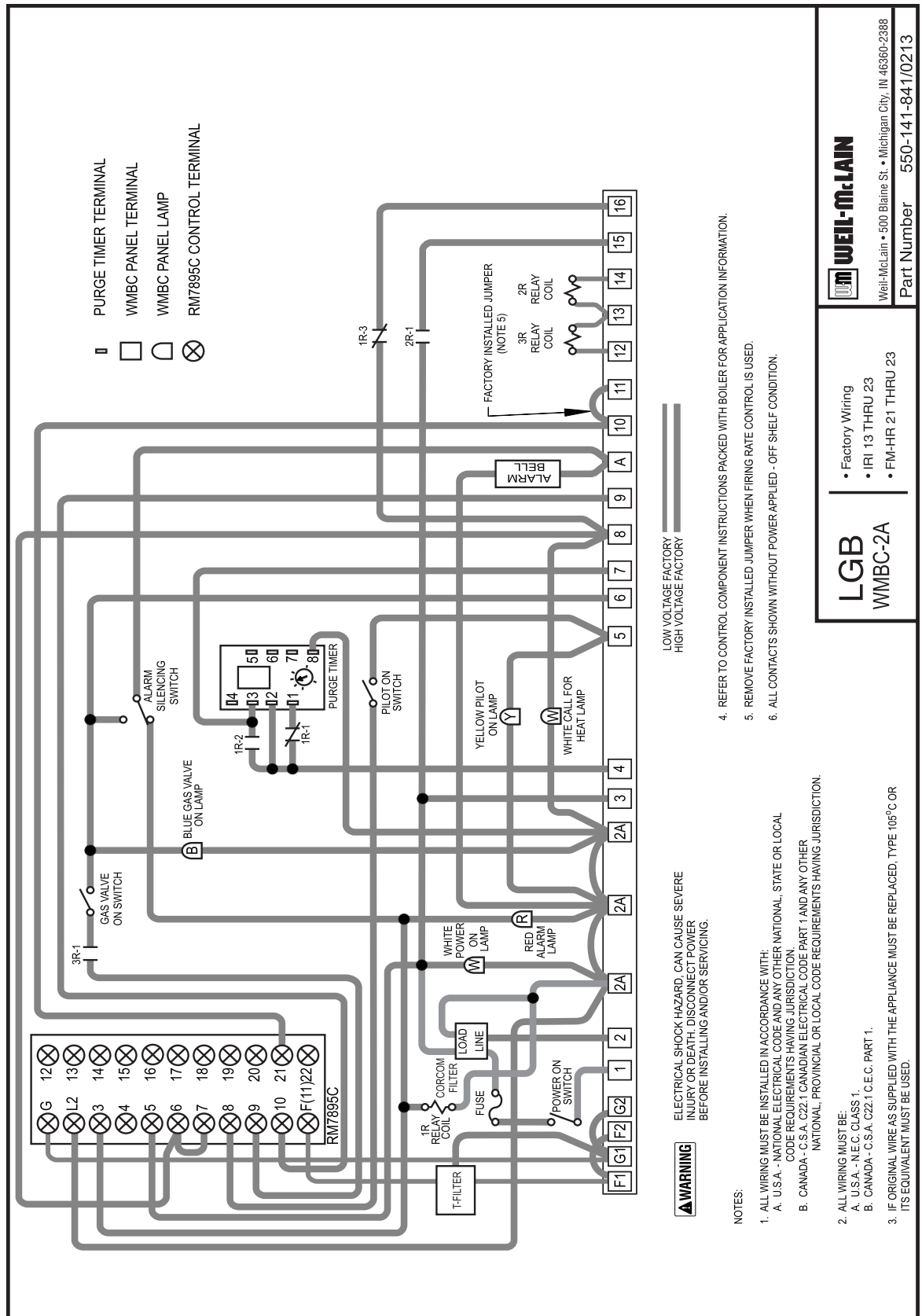









## Start-up



Turn off electrical power supply and gas supply to boiler before making the following connections and adjustment. Failure to do so can cause severe personal injury, death or substantial property damage.

1. Disable high fire by disconnecting the blue wire in the two-stage gas valve.
2. Connect manometer to gas manifold (manometer must be capable of measuring 0” to 14” W.C.).
3. Turn on electrical power supply and gas supply to boiler.
4. Fire boiler, which will light off and remain on low fire.
5. While reading manometer, turn low fire adjustment screw clockwise (Figure 5) until pressure reading is 1.2” W.C.
6. Turn off boiler.



Turn off electrical power supply and gas supply to boiler before the following steps. Failure to do so can cause severe personal injury, death or substantial property damage.

7. Remove manometer from manifold and plug the tapping.
8. Reconnect the blue wire in the two-stage gas valve junction box.
9. Turn on electrical power supply and gas supply to boiler.
10. Follow operating instructions label on boiler to set boiler in operation.

**Figure 9** Low fire adjustment

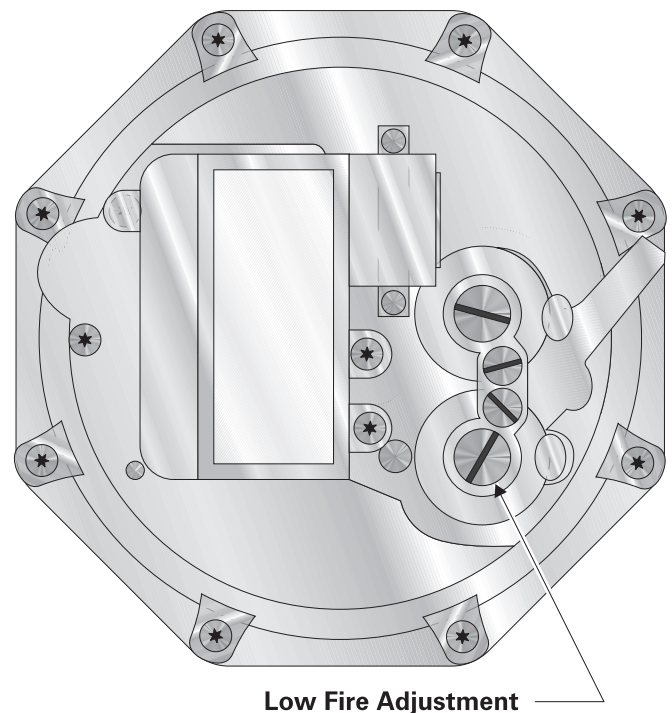



---

## Water and Steam trim components

1. Install water or steam trim components as required by CSD-1 latest edition. See the boiler manual for tapping locations.
  - a. Water boilers require:
    - a manual reset high temperature limit control in addition to the standard automatic reset limit control.
    - a manual reset low water cutoff.
  - b. Steam boilers require:
    - a manual reset high pressure limit control in addition to the standard automatic reset limit control.
    - a manual reset low water cutoff in addition to the standard automatic reset low water cutoff.

---

## Sequence of operation

1. Operating control begins start-up sequence:
  - a. Limit control contacts are closed.
  - b. Purge timer is energized.
2. Flame safeguard control pilot circuit energizes after 2.0 seconds.
  - a. Pilot gas valve opens.
  - b. Ignition transformer energizes.
  - c. Yellow “pilot on” lamp lights.
  - d. Pilot ignition spark begins.
  - e. Pilot ignites.
  - f. Pilot flame proves.
3. No. 2 Universal Spark Control energizes.
  - a. Pilot gas valve opens.
  - b. Pilot ignition spark begins.
  - c. Pilot ignites.
  - d. Pilot proves. Ignition spark stops.
  - e. Pilot continues to burn during boiler “on” cycle.
4. Flame safeguard control energizes main flame circuit:
  - a. No. 2 Universal Spark Control operates main gas controls.
  - b. Blue “gas valve on” lamp lights.
  - c. Gas control train energizes.
  - d. Downstream gas valve opens to low-fire position.
  - e. Main burners ignite, operate at low fire.
5. No. 1 pilot ignition transformer de-energizes after 10-second trial for ignition.
6. No. 1 pilot extinguishes after 10-second trial for main flame. Yellow “pilot on” lamp goes out.
7. Main flame sensor proves main burner operation at low fire.
8. Flame safeguard control switches downstream gas valve to high-fire (through firing rate control, when used):
  - a. Main burners operate at high fire.
  - b. Main burners operate at low fire when water temperature or pressure reaches setting of firing rate control, when used.
9. Boiler shuts down when operating control satisfied.
10. Flame safeguard control locks out circuit if pilot is not proved during start-up or if No. 2 pilot and main burner flames are not proved during run cycle:
  - a. Flame safeguard control locks out on safety.
  - b. Red “alarm” lamp, alarm relay, and alarm bell energize. Silencing switch can shut off alarm bell.
  - c. Alarm relay de-energizes purge timer.
  - d. Press reset button on flame safeguard control to permit normal start-up after correcting lockout condition.
  - e. Normal start-up resumes after purge timer automatically resets (5 minute enforced wait)



## Replacement part list - Table 3

Description	Size	Supplier/Part Number	Weil-McLain Part Number
Primary Control		Honeywell RM7895C1012	510-350-431
Prepurge Timing Card 2.0 Seconds		Honeywell ST7800A1005	510-350-432
Flame Amplifier		Honeywell R7847A1033	510-350-434
Electric Bulb 120V		Svlv. 120 MB/CHI Min. CM8-967	*
Fuse 6 Amp.		Bussman MTH-6	*
Control Relay 120V DPDT		Honeywell R4222D1013	510-311-012*
Control Relay 24V SPST		Honeywell R8222D1002	510-350-221*
Control Timer		SSAC EDRM427	510-350-430
Gas Cock, 1/4 M X 1/4 F		Conbraco 53-300-01	*
Pilot Regulator, 1/4 NPT		Maxitrol RV20A	*
Pilot solenoid	1/4"	Honeywell V4046C1021 Johnson Control H91ABA-12C	511-044-040*
Brass Union, 1/8 NPT X 1/4cc			*
Low Gas Pressure Switch		Honeywell C6097A1012	511-624-550*
High Gas Pressure Switch		Honeywell C6097B1028	511-624-555*
Gauge Cock	1/4"	Conbraco 41-560-05	571-210-415*
No. 1 Pilot burner		Honeywell Q179C1009	511-330-164
No. 2 Pilot burner		Johnson Controls Q90GE-1 Beckett E48A-1	511-330-166
Pilot Bracket		Weil-McLain	460-005-624
Main Flame Sensor		Honeywell 392956	511-724-274
Main Flame Sensor Bracket		Weil-McLain	423-300-420
Main Burner with Bracket		Weil-McLain	512-200-055
Ignition Transformer		Honeywell Q624A1014	511-802-014*
UCS Control Module		Honeywell S8620C1003 United Technologies 1003-611A	571-330-097
Hand Valve	1 1/2"	Conbraco 50-603	*
	2"	Conbraco 50-703	
	2 1/2"	Conbraco 50-803	
Lub. Plug Cock	3"	Columbia R-1430	*
Valve body (small - 1-1/2" & 2" Pipe Flanges)		Honeywell V5097A1004	510-744-315
Valve body (large - 2 1/2" & 3" Pipe Flanges)		Honeywell V5097A1012	510-744-316
Pipe Flanges (for Valve Body)	1 1/2"	Honeywell 32000109-004	511-044-172
	2"	Honeywell 32000109-005	511-044-173
	2 1/2"	Honeywell 32001605-002	511-044-174
	3"	Honeywell 32001605-003	511-044-175
Actuator for Valve Body (On/Off)		Honeywell V4055A1098	510-744-317
Solenoid Vent Valve (Normally open)	3/4"	Honeywell V4295S1005	511-046-340
	1"	Honeywell V4295S1013	511-046-342
	1 1/4"	Honeywell V4295S1021	511-046-344
Adapter for small valve body (for vent valve)		Honeywell V32002513	511-044-176
Adapter for large valve body (for vent valve)		Honeywell V32002512	511-044-177
Gas Valve with Regulator	1"	Honeywell V4944N1011	511-048-503
	1 1/4"	Honeywell V4944N1029	511-048-502
	1 1/2"	Honeywell V4944N1037	511-048-501
	2"	Honeywell V4944N1045	511-048-500
EMI Line Filter		Corcom 10VS1	590-216-501
T-Filter		Honeywell 32005301-001	590-216-502
Ignition Transformer		Dongan A06-SA6	511-802-625
Wire 18 Gauge High Temperature (20 feet)		Weil-McLain	590-849-236*

\* Listed part can be purchased at local supply house

